



TRUE RESIDENTIAL®

15 INCH CLEAR ICE MACHINE
B VERSION
SERVICE MANUAL



PRESERVE THE MOMENT®



811685-A

THANK YOU

FOR YOUR PURCHASE

INSTALLATION CHECKLIST

To ensure no part of the installation process has been overlooked, complete the checklist below.

- Has an authorized True dealer or licensed installer inspected stainless steel surfaces for imperfection? (Cosmetic defects are covered by a limited 30-day warranty)
 - Is the water pressure between 20-80 PSI?
 - Have all packaging materials and tape been removed?
 - Is the water temperature always between 40°F (4°C) and 100°F (38°C)?
 - Is the power cord plugged into a properly grounded 115v 15 amp dedicated three-prong outlet in accordance with all applicable electrical codes?
 - Have the water supply and drain connections been made?
 - Has the ice machine drain line been routed to follow plumbing code with no more than 7' (2.1m) of rise and 100' (33m) of run?
 - Is the unit leveled properly with all leveling legs making contact with the floor?
 - Has the door stop been installed? (If desired)
 - Are panels attached securely and properly aligned? (Overlay cabinets only)
 - Has the machine been set for the local water quality?
 - Has the water filter been installed?
- NOTE: THE MACHINE WILL NOT OPERATE WITHOUT THE FILTER INSTALLED**
- Is the water supply turned on?
 - Have the connections been checked for water leaks?
 - Is the machine turned on and working properly?
 - Have the first two batches of ice been discarded?
 - Does the machine shut off when ice is held against the thermostat tube?
 - Has the customer reviewed the schedule of maintenance of the machine?

TRUE'S TECHNICAL SERVICE YOUTUBE CHANNEL

For more in-depth installation and service information, see our Technical Service YouTube Channel at <https://www.youtube.com/TrueManufacturingService>



CONTENTS

SAFETY INFORMATION & OWNERSHIP

APPLIANCE FEATURES	8
SAFETY WARNINGS	8
PROPER DISPOSAL OF OLD ICE MACHINES	9
OWNERSHIP	9
WARNING & SAFETY LABELS	9
AMBIENT PRESSURES & WATER PRESSURES	10
OUTDOOR USE	10
ELECTRICAL INSTALLATION & SAFETY	11
SERIAL LABEL LOCATION	12
ANTI-SWEAT FOAM END PANELS	12

INSTALLATION & SETUP

WATER SUPPLY	14
PLUMBING CONNECTIONS	14
WATER FILTER	15
DRAIN CONNECTION	15
OTHER DRAIN CONNECTIONS	15
PUMPING HEIGHTS	16
DRAIN ALARM (DRN)	16
INSTALLING THE DOOR STOP	17
90° DOOR STOP INSTALLATION	18
LEVELING	20
KICKPLATE INSTALLATION	20

NOTE: AS WE STRIVE FOR CONTINUOUS IMPROVEMENTS, FEATURES AND SPECIFICATIONS ARE SUBJECT TO CHANGE WITHOUT NOTICE.

APPLIANCE OPERATION

DISPLAY CODE DEFINITIONS	22
TRUE PRECISION CONTROL® OPERATION	26
STANDBY MODE	28
STARTUP SEQUENCE OF OPERATION	29
NORMAL OPERATION	31
BIN LIGHT	33
CUBE SIZE ADJUSTMENT	33
BIN THERMOSTAT	33
ICE LEVEL ADJUSTMENT	34
BREAKER RESET	34
WATER QUALITY SETTING	34

MAINTENANCE & SERVICE

GENERAL MAINTENANCE	34
INTERIOR COMPONENTS	35
WATER FILTER REPLACEMENT	38
SERVICING & REPLACING COMPONENTS	39
CONDENSER CLEANING	39
APPLIANCE CARE & CLEANING	40
DESCALING & SANITIZING	42
EXTERIOR CLEANING	43
WINTERIZING INSTRUCTIONS	44

TROUBLESHOOTING

VERIFYING COMPONENT VOLTAGE	46
DOOR CLOSING & SEALING ISSUES	47
THERMISTOR LOCATIONS	51
THERMISTOR VALUES	51
FREEZE CYCLE SEQUENCE & CHART	52
HARVEST CYCLE SEQUENCE & CHART	54
FREQUENTLY ASKED QUESTIONS	56
WIRING DIAGRAM	57

APPLIANCE FEATURES

SAFETY PRECAUTIONS

PROPER DISPOSAL OF OLD ICE MACHINES

OWNERSHIP

WARNING & SAFETY LABELS

AMBIENT PRESSURES & WATER PRESSURES

SERIAL LABEL LOCATION

OUTDOOR USE

ELECTRICAL INSTALLATION & SAFETY



PRESERVE THE MOMENT®

FEATURES OF THE TRUE™ ICE MACHINE

- Produces up to 70 lbs (31.8 kg) of ultra-clear gourmet ice cubes per day.
- Stores 28 lbs (12.7 kg) of ice cubes.
- Three-character LED display tells you what your machine is doing.
- Auto-clean sequence for walk-away cleaning simplicity.
- Cleaning time remaining is shown on the display.
- Drain pump standard on all models.
- Built-in water filter ensures that no parts are exposed to unfiltered water.
- Fourteen-color LED bin light.
- High quality ice scoop and built-in scoop holder included.
- Automatic filter change reminder.
- UL approved for outdoor use.
- Industry-leading True Warranty.

SAFETY WARNINGS

Install and locate this ice machine in accordance with the installation instructions before use. Proper installation requires connection to a water supply, a drain, and a dedicated electrical circuit. The installer is responsible for these connections.

THE ICE MACHINE MUST BE INSTALLED ACCORDING TO ALL APPLICABLE NATIONAL, STATE, AND LOCAL CODES AND REGULATIONS.

WARNING: IMPROPER CONNECTIONS CAN RESULT IN PERSONAL INJURY, PROPERTY DAMAGE, AND IMPROPER OPERATION.

- Do not allow children to climb, stand, or hang on the ice machine. This could damage the unit and cause severe personal injury.
- Do not store or use gasoline or other flammable/combustible/explosive vapors, liquids, or substances in the vicinity of this or any other appliance.

- Keep hands away from pinch-point areas and gaps between the doors and cabinet.
- Unplug the ice machine before cleaning behind the kickplate or making repairs.
- Setting power switch to **OFF** only removes power from the refrigeration system; it does not remove power from other circuits. Unplug the machine or disconnect power to fully power it down.
- Take care when moving, installing, cleaning, servicing, and maintaining the appliance to avoid cuts. Be sure to take care when reaching under the appliance or handling metal components.
- Use appropriate tools, safety equipment, and personal protective equipment (PPE) during installation and servicing.
- **DO NOT** touch the cold surfaces in the freezer compartment when hands are damp or wet. Skin may stick to these extremely cold surfaces.
- This appliance is not to be used, cleaned or maintained by persons (including children) with reduced physical, sensory or mental capabilities or lack of experience and knowledge, unless they have been given supervision or instruction.
- Units may pose a tipping hazard while uncrating, during installation, or when moving the unit.

NOTE: SERVICING SHOULD BE PERFORMED BY QUALIFIED PROFESSIONALS.

PROPER DISPOSAL OF OLD ICE MACHINES



Child entrapment and suffocation continue to be problems today. Junked or abandoned ice machines are still dangerous, even if they sit for “just a few days.” If disposing of your old ice machine, please remove the door and follow the CFC disposal instructions below to prevent accidents.

CFC DISPOSAL

Old ice machines may have a cooling system that used chlorofluorocarbons (CFCs) as refrigerant. CFCs harm the stratospheric ozone. When disposing old ice machines, ensure the CFC refrigerant is removed for proper disposal by a qualified service.

Intentionally releasing CFC refrigerant into the atmosphere, may result in fines and imprisonment under provisions of the environment legislation.

TAKE OFF THE DOOR BEFORE THROWING AWAY YOUR OLD ICE MACHINE.

OWNERSHIP

TO ENSURE YOUR UNIT WORKS PROPERLY FROM THE FIRST DAY, IT MUST BE INSTALLED CORRECTLY.

NOTE: WE HIGHLY RECOMMEND A TRAINED INSTALLER, PLUMBER, OR ELECTRICIAN INSTALL YOUR TRUE RESIDENTIAL® ICE MACHINE. THE COST OF A PROFESSIONAL INSTALLATION IS MONEY WELL SPENT.

Before you start installing your True Residential® Ice Machine, carefully inspect it for freight damage. If damage is discovered, immediately file a claim with the delivery freight carrier. **DO NOT install the unit or put it in service.** True Residential is not responsible for damage incurred during shipment.

If you have any questions about installation, contact your True dealer or True Technical Support Department at 844-746-9423. Please have your model and serial numbers available when you call our Technical Support Department.

WARNING & SAFETY LABELS



CAUTION: Located on the back of the unit.

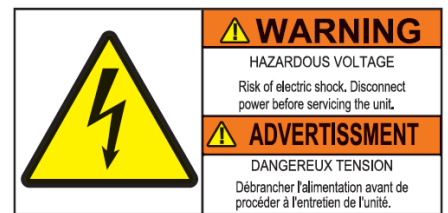

WARNING: Located on the back of the unit.

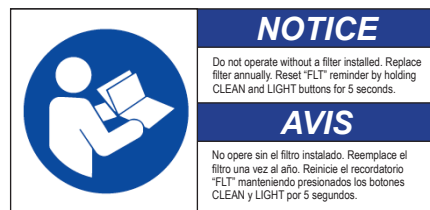

NOTICE: Behind front door next to water filter.

AMBIENT TEMPERATURES & WATER PRESSURES

Do not expose the ice machine to temperatures below 32°F (0°C) or water in the machine will freeze.

Winterize the unit. See “Winterizing Instructions” (pg 44).

FAILURES RESULTING FROM EXPOSURE TO FREEZING TEMPERATURES ARE NOT COVERED BY WARRANTY.

Ambient Operational Temperatures and Water Pressures		
	Minimum	Maximum
Air Temperature	40°F (4°C)	100°F (38°C)
Water Temperature	40°F (4°C)	100°F (38°C)
Water Pressure	20 PSI (1.4 BAR)	80 PSI (5.5 BAR)

*Max Ice Production	70 lbs (31.8 kg)/day
**Rated Ice Production	57 lbs (25.9 kg)/day

* Performance Rated at 70°F air / 50°F water / 30 PSIG water pressure.
 ** Performance Rated at 90°F air / 70°F water / 30 PSIG water pressure.

OUTDOOR USE

All True undercounter ice machines are UL-rated for outdoor use.

WHEN INSTALLING YOUR UNIT OUTDOORS, REMEMBER TO CONSIDER THE AMBIENT TEMPERATURE.

Certain regions experience colder ambient temperatures than others. When this decrease in temperature occurs, the unit may stop producing ice before it is full and reads **FUL** on the display. The internal thermostat has reached the cut-off temperature. Additionally, stainless steel cabinets are heavily insulated and retain the cold temperature for long periods of time.

The unit’s physical location also plays a factor in false full readings. If the unit is built into a kitchenette area (within stone, brick, wood, etc.), this will further delay the reaction time. Even if ambient temperatures increase during the day, your cabinet may be holding the colder temperature from the previous evening.

If your unit shows a false full reading, rub your hand on the inside ice level bar. Once it senses the warm temperature, it will produce ice again.

During colder periods of temperature, True recommends increasing the ice level with the adjustment screw behind the front louver grill. The level can be increased by turning the screw clockwise.

If the unit is expected to be exposed to low air temperatures for a prolonged period of time, please turn the unit off and winterize the unit. See “Winterizing” (pg. 44).



NOTICE: DO NOT ALLOW THE ICE MACHINE TO BE EXPOSED TO TEMPERATURES BELOW 32°F (0°C) WITHOUT WINTERIZING THE UNIT AS THIS WILL CAUSE ANY WATER IN THE MACHINE TO FREEZE. FAILURES CAUSED BY EXPOSURE TO FREEZING TEMPERATURES ARE NOT COVERED BY THE WARRANTY.

ELECTRICAL INSTALLATION & SAFETY



The unit is approved by UL for outdoor installation.

USE OF ADAPTER PLUGS

NEVER USE AN ADAPTER PLUG! An adapter plug alters the original OEM plug configuration when connecting it to a power source.



TRUE will not warranty any ice machine that has been connected to an adapter plug.

USE OF EXTENSION CORDS

NEVER USE AN EXTENSION CORD! An extension cord is determined to be any component that adds length to the original OEM power cord when connecting it to a power source.



TRUE will not warranty any ice machine that has been connected to an extension cord.

HOW TO CONNECT ELECTRICITY

- The ice machine should always be plugged into an individual dedicated electrical circuit. This provides the best performance and prevents building wiring circuits from being overloaded, which could cause a fire hazard from overheated wires.
- Before your new unit is connected to a power supply, check the incoming voltage with a voltmeter. If the recorded voltage is less than the rated voltage for operation (+/-5%) and amp rating, correct immediately. Refer to appliance data plate for this voltage requirement.
- The electrical outlet must be within 36" (914.4 mm) of the center of the back wall of the ice machine's final location. Outlet must be flush with wall and comply with local electrical codes.

- The wall outlet and circuit should be checked by a licensed electrician to make sure the outlet is properly grounded.
- The power cord of this appliance is equipped with a 3-prong (grounding) plug which mates with a standard 3-prong (grounding) wall outlet to minimize the possibility of electric shock hazard from this appliance. A 115V AC, 60 Hz, 15 amp circuit breaker and electrical supply are required.
- If the outlet is a standard 2-prong outlet, it is your personal responsibility and obligation to have it replaced with the properly grounded wall outlet.
- **DO NOT**, under any circumstances, cut or remove the ground prong from the power cord. For personal safety, this appliance must be properly grounded.
- When moving the ice machine, for any reason, be careful not to roll over or damage the power cord.
- Repair or replace immediately all power cords that have become frayed or otherwise damaged. **DO NOT** use a power cord that shows cracks or abrasion damage along its length or at either end.
- If the supply power cord is damaged, it should be replaced with original equipment manufacturer (OEM) components. To avoid hazard this should be done by a licensed service provider.
- **NEVER** unplug your ice machine by pulling on the power cord. Always grip plug firmly and pull straight out from the outlet.

WARNING: THIS APPLIANCE MUST BE PROPERLY GROUNDED. DO NOT, UNDER ANY CIRCUMSTANCES, CUT OR REMOVE THE THIRD (GROUND) PRONG FROM THE POWER CORD. HAVE A QUALIFIED ELECTRICIAN CHECK IF THE WALL OUTLET IS PROPERLY GROUNDED.

ANTI-SWEAT FOAM END PANELS

When installing two or more True units side-by-side, TRUE recommends installing one (1) foam pad between the appliances (on either appliance) to prevent moisture from developing.

To order foam pads, contact our parts department at **844-849-6226** or **TrueResidentialParts@TrueMfg.com**.

SERIAL LABEL LOCATION

Your serial label contains important information such as your model and serial number. The label is located on the upper left interior wall. See fig. 1.

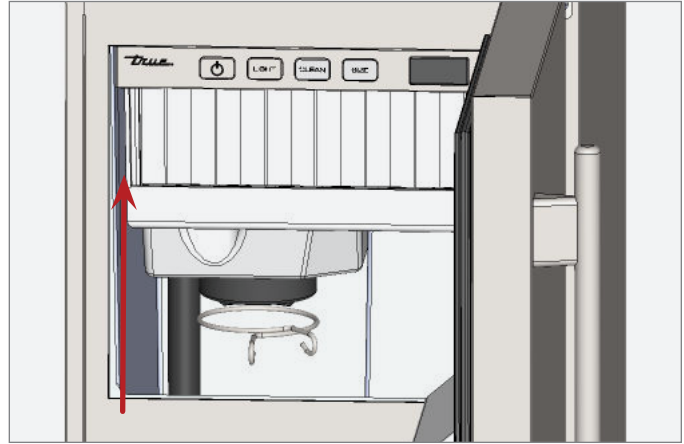

FIG. 1. Serial label location.

WATER SUPPLY

PLUMBING CONNECTIONS

WATER FILTER

DRAIN CONNECTION

OTHER DRAIN CONNECTIONS

DRAIN ALARM (DRN)

INSTALLING THE DOOR STOP

90° DOOR STOP INSTALLATION

LEVELING

KICKPLATE INSTALLATION



PRESERVE THE MOMENT®

WATER SUPPLY

- Locate the water supply.
- Connect the water supply line to the house supply with an easily accessible shut-off valve between the water supply and the ice machine.

WATER PRESSURE MUST BE BETWEEN 20 PSI (1.4 BAR) AND 80 PSI (5.5 BAR). IF THE WATER PRESSURE EXCEEDS THE MAXIMUM PRESSURE, INSTALL A WATER PRESSURE REGULATOR.

- A reverse osmosis system can be used, provided there is constant water pressure of 20 psi (1.4 bar) to 80 psi (5.5 bar) supplied to the ice machine at all times. A copper line is not recommended for such applications. When switching to PEX, the tubing must be rated for a minimum of 150 PSI burst pressure and 180°F.
- A cold water supply line must be supplied to the ice machine. Use 1/4" O.D. copper, braided stainless steel, or PEX tubing and compression fittings. A copper line is not recommended for this application.
- The incoming water temperature must remain between 40° F (4°C) and 100°F (38°C).
- Insulate the water supply line to prevent condensation.
- Do not connect the ice machine to a hot water supply. Be sure all hot water restrictors installed for other equipment are working, such as check valves on sink faucets, dishwashers, etc.

PLUMBING CONNECTIONS

Before installing your ice machine, prepare the water supply line and drain connections. The ice machine must be installed with adequate clearance for water and drain connections at the rear of the unit.

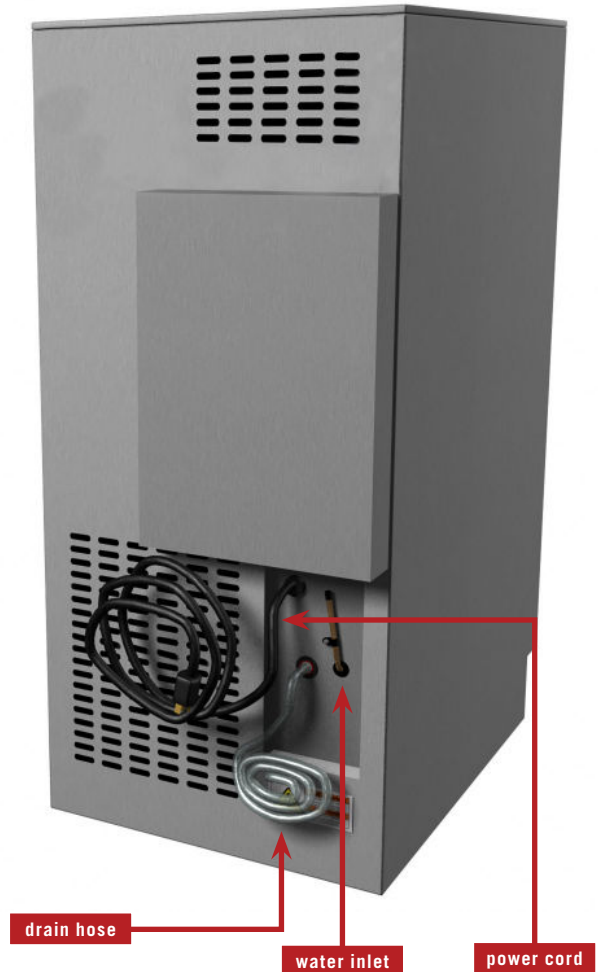

Plumbing

Water Supply: 1/4" O.D. copper, braided stainless steel or PEX tubing and compression fittings (1/4" lines and fittings not included)

Drain Pump Connection: Supplied with 84" of 3/8" O.D. plastic tubing

WATER FILTER

The built-in water filter is designed to filter sediment, remove unpleasant taste and odor, and inhibit scale (mineral deposits). The life expectancy of the filter is twelve months for low scale (soft) water and six months for high scale (hard) water. The ice machine monitors how long the filter has been in operation and will display **FLT** when the filter needs to be replaced. It will read **FLT** until the message is reset by pressing and holding the Clean & Light button.

NOTICE: INSTALL THE WATER FILTER BEFORE TURNING ON THE WATER SUPPLY TO THE ICE MACHINE.

NOTICE: DO NOT ALLOW THE ICE MACHINE TO BE EXPOSED TO TEMPERATURES BELOW 32°F (0°C) WITHOUT WINTERIZING THE UNIT (PG. 44) THIS WILL FREEZE ANY WATER IN THE MACHINE. FAILURES CAUSED BY EXPOSURE TO FREEZING TEMPERATURES ARE NOT COVERED BY THE WARRANTY.

DRAIN CONNECTION

The True Ice™ machine has a built-in drain pump that will pump water up to a drain point, such as a sink.

- 7' (2.1m) of 3/8" O.D. plastic tubing is supplied with the ice machine.
- The drain pump has a maximum rise of 7' (2.1 m) and a maximum run of 100' (33m). If the rise is higher than 7', an optional pump may be required.
- The floor drain must be large enough to accommodate drainage from all drain lines.
- The drain pump discharge line must terminate at an open site drain.

OTHER DRAIN CONNECTIONS

OPTION 1

A 3/8" to 3/8" O.D. adapter is provided to extend the plastic tubing provided.



OPTION 2

A 3/8" push fitting to 5/8" O.D. (1/2" I.D.) barb adapter is also provided. Use this fitting in conjunction with the union adapter below, or remove the 3/8" O.D. hose and plug the adapter directly into the check valve.

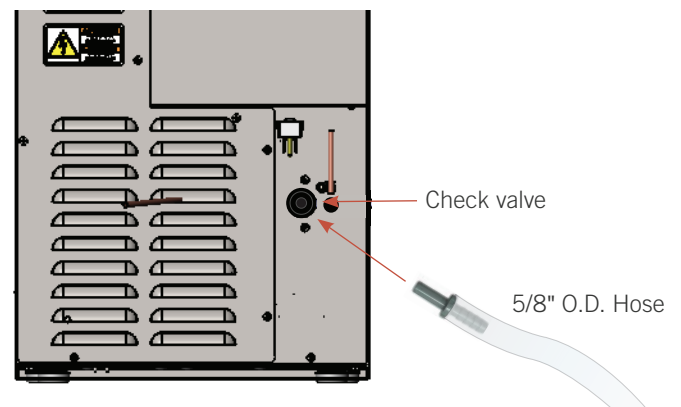
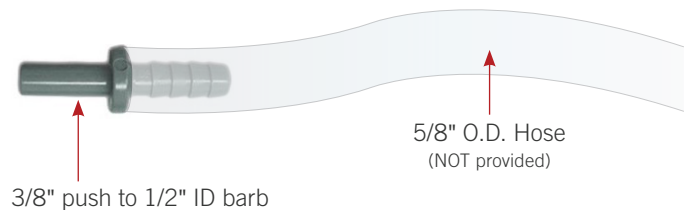
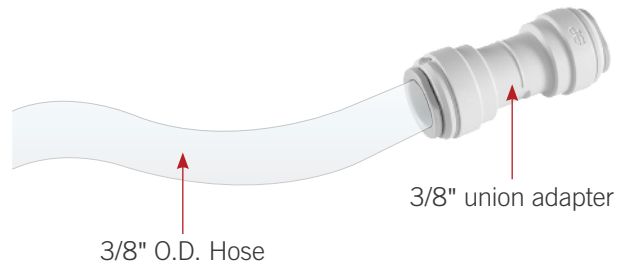

PUMPING HEIGHTS

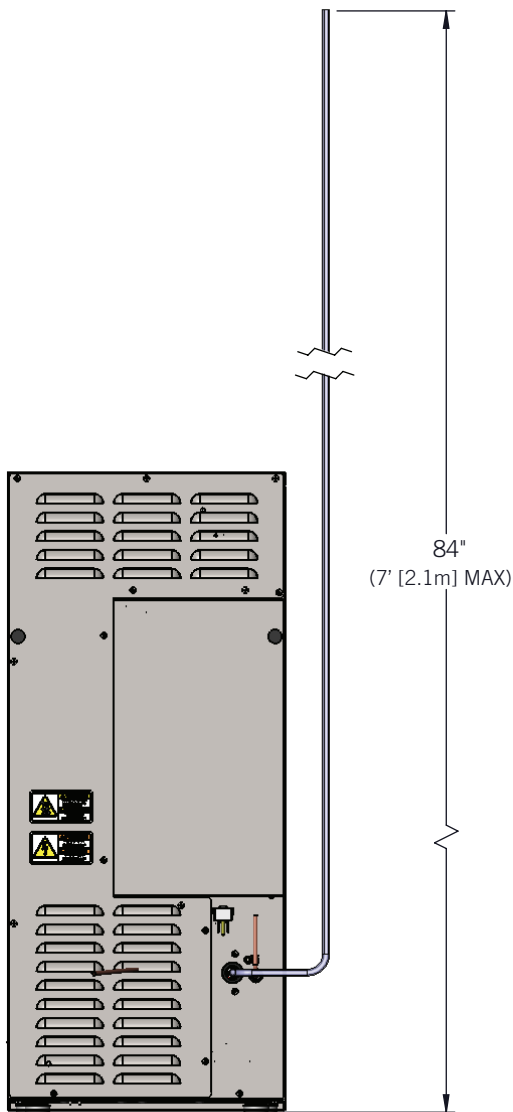

STANDARD PUMP
WITH 3/8" O.D. HOSE

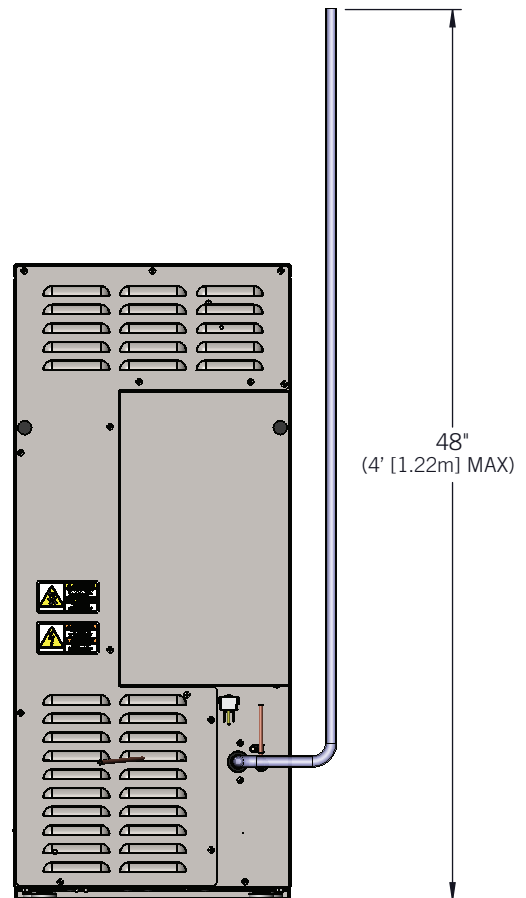

STANDARD PUMP
WITH 5/8" O.D. HOSE

DRAIN ALARM (DRN)

THE DRAIN ALARM IS INITIATED BY THE CONTROL BOARD IN THE EVENT OF IMPROPER DRAINAGE.

- The control monitors power at the pressure switch. If the drain pump runs continuously for five (5) minutes, the unit will shut down and display **DRN** in the message window.
- Ensure the drain line is not kinked, bent, smashed, or bound in any way.



CAUTION: ADHERE TO LOCAL AND STATE PLUMBING CODES. DO NOT EXCEED THE MAXIMUM PLUMBING HEIGHTS FOR YOUR GIVEN SETUP.

VERIFY THE ICE MACHINE DRAINS THROUGH TWO CYCLES WITHOUT ANY ALARM DURING INSTALLATION.

INSTALLING THE DOOR STOP

All units are provided with an optional door stop. When installed, the door stop restricts the door from opening past approximately 120° to prevent damage to surrounding cabinetry.

All overlay units come standard with a 90° door hinge and door stop.

NOTE: THE DOOR STOP MUST BE INSTALLED TO PREVENT DAMAGE ON INTEGRATED DOOR PANEL.

Install the door stop with the screws located by the bottom hinge. See figs. 1-3.

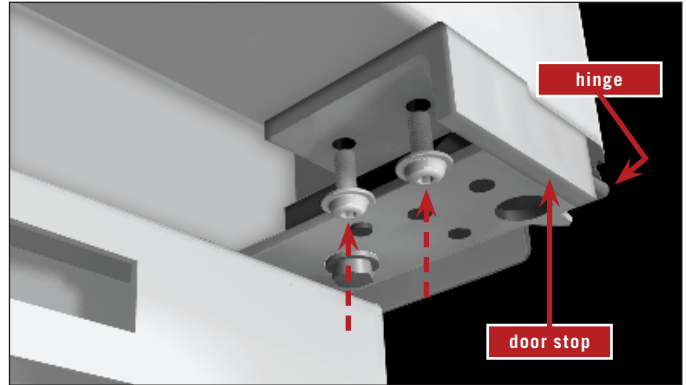

FIG. 1. Install the door stop.

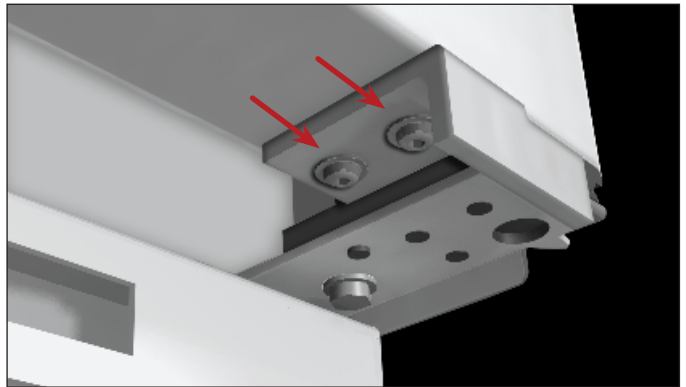

FIG. 2. Door stop screw location.

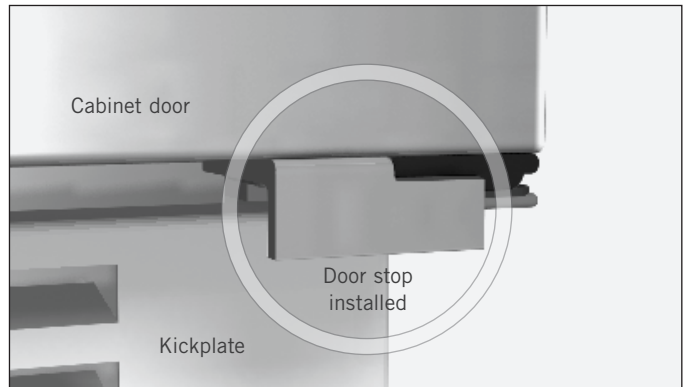

FIG. 3. Installed door stop.

90° DOOR STOP INSTALLATION (OPTIONAL)

INSTRUCTIONS FOR STAINLESS STEEL MODELS

KIT CONTENTS

- 90° Hinge (left or right)
- Door stop bracket (left or right)

REQUIRED TOOLS

- 3/8" Socket wrench
- Phillips screwdriver

PROCEDURE

1. Remove the kickplate. See fig. 1.
2. Remove the 120° door hinge. See fig. 2. Set hardware aside.

NOTE: BE SURE TO SUPPORT THE DOOR WHILE REMOVING THE HINGE. DOOR WILL DROP IF NOT SUPPORTED.

3. Remove the door. See fig. 3.
4. Install door stop using screws already installed. See fig. 4. Reinstall door by sliding up into top hinge.



FIG. 1. Carefully remove the kickplate.

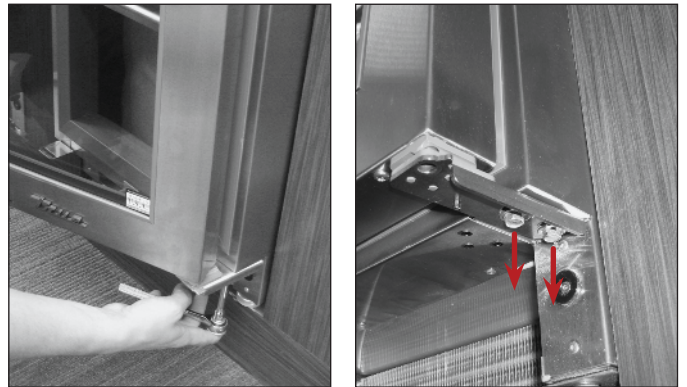

FIG. 2. Bottom hinge bolt location.

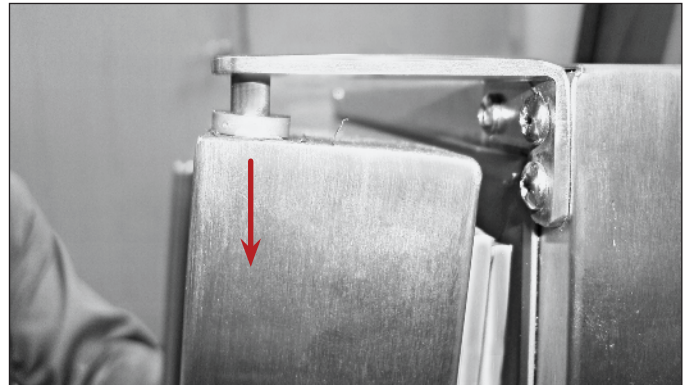

FIG. 3. Slide the door down from the top hinge to remove it.

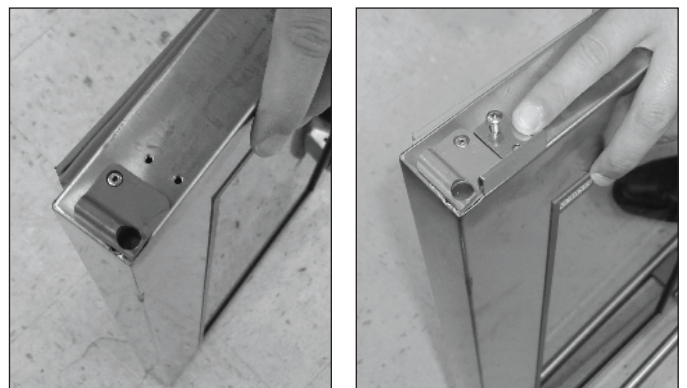

FIG. 4. Door stop screw location.

90° DOOR STOP INSTALLATION (OPTIONAL) (CONT.)

5. Install 90° hinge with the two 3/8" bolts. See fig. 5.

NOTE: DO NOT FULLY TIGHTEN THE HARDWARE UNTIL DOOR ADJUSTMENTS HAVE BEEN MADE.

6. Align door with lock latch and light switch. Tighten screws (see fig. 6).



FIG. 5. Install the 90° door hinge. Do not fully tighten hardware.



FIG. 6. Tighten the bottom hinge hardware after adjusting the door alignment.

LEVELING

Proper leveling of your ice machine is critical to operating success. Leveling effects drainage and door operation.

PROCEDURE

1. Set the unit in its final location. Be sure there is adequate ventilation in your room.
2. Verify the unit's level. On the unit's top, check the level front-to-back and side-to-side. See fig. 1.
3. Turn the leveling legs as needed to adjust the level. See fig. 2.

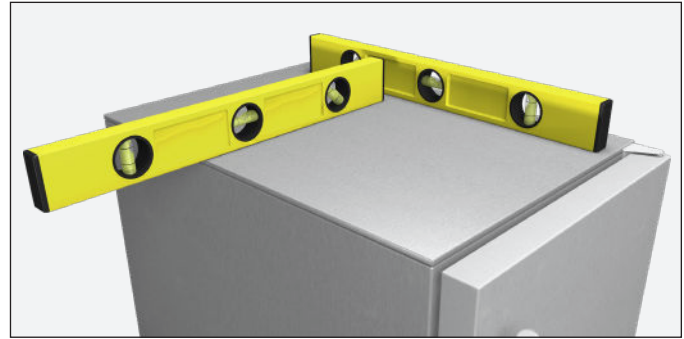

FIG. 1. Check the level from the top of the unit.

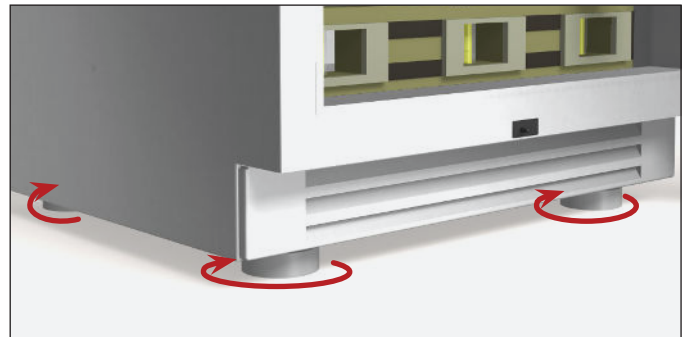

FIG. 2. Turn the leveling legs clockwise to lower the unit or counterclockwise to raise the unit.

KICKPLATE INSTALLATION

The kickplate is shipped unattached to the unit to allow easy access for leveling. The kickplate attaches to the unit with magnets at the bottom of the unit.

INSTALLATION

1. After leveling the unit, position the kickplate below the door. See fig. 1
2. Verify the kickplate is correctly aligned. Adjust as needed.

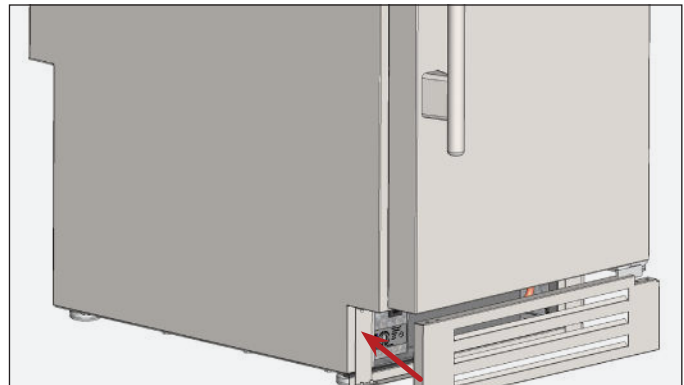

FIG. 1. Attach the kickplate to the magnets below the door.

REMOVAL

Pull the kickplate away from the unit.

DISPLAY CODE DEFINITIONS

TRUE PRECISION CONTROL® OPERATION

STARTUP SEQUENCE OF OPERATION

NORMAL OPERATION

BIN LIGHT

CUBE SIZE ADJUSTMENT

BIN THERMOSTAT

ICE LEVEL ADJUSTMENT

BREAKER RESET

WATER QUALITY SETTING



PRESERVE THE MOMENT®

DISPLAY CODE DEFINITIONS

Display Code	Definition	Notes
	Making Ice	Circulation pump is running, spraying water into the molds to make cubes.
	Harvesting Ice	Water will fill for the next batch of ice and drop the ice in the molds.
	Fill	Water is filling the reservoir and will run for 2-3 minutes.
	Bin is Full	Ice has reached the bar located on the interior right hand wall.
	Drain Pump Failure	Clogged or kinked drain line. Drain was not able to clear within 5 minutes of running. During a drain error, the machine can only be restarted when the display alternates between drn and oFF.
	Thermistor 1 Failure	Thermistor 1 is located in condenser discharge air. Probe is open or has a loose connection at control board.
	Thermistor 2 Failure	Thermistor 2 is located on the suction line by the evaporator coil. Probe is open or has a loose connection at control board.
	Ambient too Hot	Condenser discharge thermistor reached 155°F.

APPLIANCE OPERATION

DISPLAY CODE DEFINITIONS (CONT.)







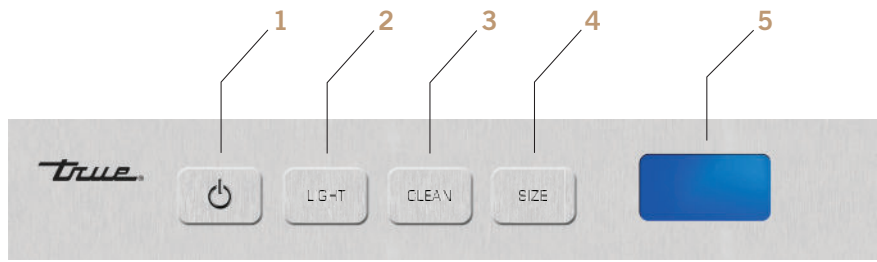

Display Code	Definition	Notes
	System too Hot	Suction line evaporator thermistor reached 155°F.
	Ambient too Cold	Condenser discharge thermistor reached 50°F.
	System too Cold	Suction line evaporator thermistor reached 5 degrees within the first 10 minutes of ice mode.
Blank Display	Blank display/buttons not responding	Remove power from the unit for 15 seconds and then restart the machine.

APPLIANCE OPERATION

TRUE PRECISION CONTROL® OPERATION

1. Power Button
2. Bin Light
3. Initiate Cleaning Sequence
4. Adjust Cube Size
5. Display







Keys/Actions	LCD Readouts	Description
 Off/On (hold 3 sec)		Power unit off/on.
 Replace Water Filter (hold 3 sec)		Unit will shut down. Change water filter, clean, and sanitize machine.
 Color		Switch LED colors - Slowly press and release to switch between 14 colors.
 Cube Size Setting		Factory default cube size is "2" the size can be changed from 1 to 5. 1 being the smallest and 5 being fuller interior cube.

APPLIANCE OPERATION

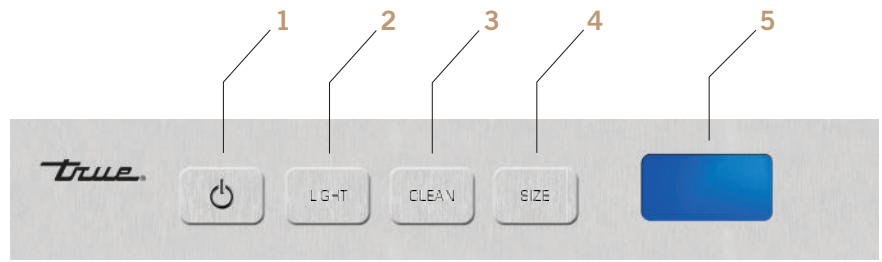
TRUE PRECISION CONTROL® OPERATION

1. Power Button
2. Bin Light
3. Initiate Cleaning Sequence
4. Adjust Cube Size
5. Display



Keys/Actions	LCD Readouts	Description
 Clean Mode (hold 3 sec)		Press and hold CLn for 3 seconds. Unit will count down from 30 to off .
 Add Cleaning Chemicals		In the clean mode. Add notification will give you 45 seconds to add the cleaners.
 Low-Scale Water (hold 3 sec)		Average water quality setting. Low scale is factory setting. Normal operation. Filter change reminder set at 1 year.
 High-Scale Water (hold 3 sec)		Below average water quality setting. Adds time to harvest. Filter change reminder set at 6 months.

STANDBY MODE

- Display will show **OFF** until the power button is pressed.
- Press and hold the power button to begin ice making operation.
- Press and hold the power button a second time to turn the ice machine off.
- When the unit is plugged in, the control board goes through a sequence of checks to verify all sensors are working properly.
- The drain system is energized when the unit is powered. It automatically turns on when it senses water in the drain tube.
- If the unit powers the drain pump but the drain remains clogged for five (5) min, the display will show **drn** and cut power to the unit.
- If unit is too cold (below 50°F (10°C), too hot, or if the temperature probe is unplugged or has failed, the unit shuts down and displays an error message.

STARTUP SEQUENCE OF OPERATION

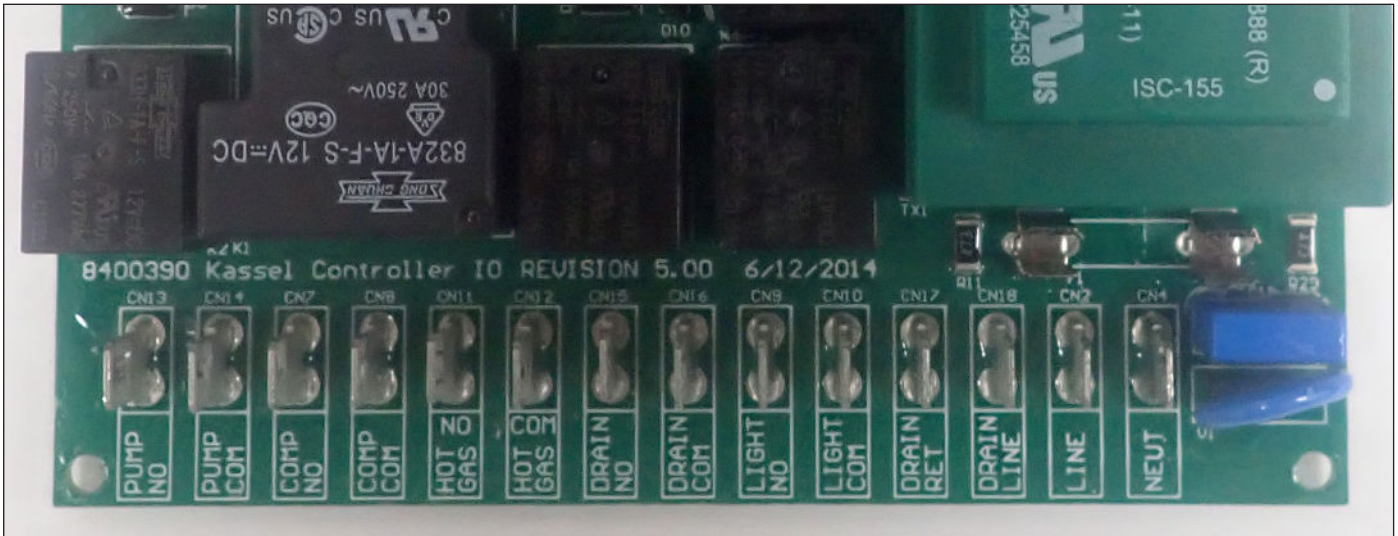

1. **FILL MODE**



- Water from the home supply flows into the filter head.
- Then it passes through the filter and back out the filter head and flows to the input side of the water inlet valve.
- When first powered on **FIL** will be displayed, 120vac is sent to the water valve and hot gas valve from terminal CN11 (Hot Gas NO) on control board.
- Water valve opens allowing water to flow up the fill tube, filling the evaporator tray, finally falling into the water reservoir via the holes in the evaporator tray.
- Fill cycle lasts 2 min on average.

	ON	OFF
Compressor		X
Condensor Fan		X
Water Valve	X	
Circulation Pump		X
Hot Gas Solenoid	X	

2. **FIRST HARVEST**



- First harvest is shorter than the harvest cycles when the unit is producing ice.
- The compressor will cycle on and the hot gas valve will be energized. This will begin circulating hot gas through the evaporator coil.
- The water valve will remain open and will continue to fill the reservoir.
- The harvest will terminate once probe 2 reaches 70°F.

	ON	OFF
Compressor	X	
Condensor Fan		X
Water Valve	X	
Circulation Pump		X
Hot Gas Solenoid	X	

STARTUP SEQUENCE OF OPERATION

3. ICE MODE



- **ICE** is displayed when unit begins the freeze cycle.
- 120vac is sent to the compressor from terminal CN7 (COMP NO) on the control board causing the evaporator to start to cool.
- 120vac is sent to circulation pump and condenser fan from terminal CN13 (PUMP NO) on the control board. Condenser fan runs and circulation pump will begin to pump water through the spray bar assembly.
- Spray bar assembly will direct water into each of the 24 ice molds (cups) that are part of the evaporator. The water will begin to freeze layer after layer forming the ice cubes.
- Freeze times are a set time and adjusted according to condenser thermistor reading.

	ON	OFF
Compressor	X	
Condensor Fan	X	
Water Valve		X
Circulation Pump	X	
Hot Gas Solenoid		X

NORMAL OPERATION

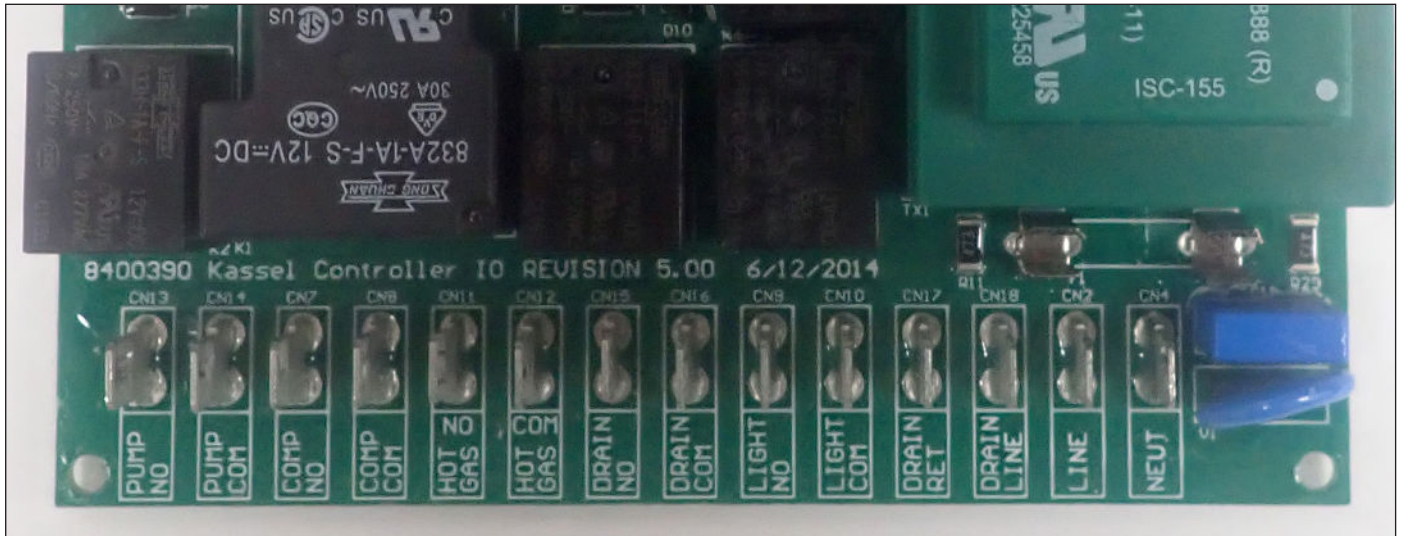

1. ICE MODE



- **ICE** is displayed when unit begins the freeze cycle.
- 120vac is sent to the Compressor from terminal CN7 (COMP NO) on the control board causing the evaporator to start to cool.
- 120vac is sent to Circulation pump and condenser fan from terminal CN13 (PUMP NO) on the control board. Condenser fan runs and circulation pump will begin to pump water through the spray bar assembly.
- Spray bar assembly will direct water into each of the 24 ice molds (cups) that are part of the evaporator. The water will begin to freeze layer after layer forming the ice cubes.
- Freeze times are a set time and adjusted according to condenser thermistor reading.

	ON	OFF
Compressor	X	
Condenser Fan	X	
Water Valve		X
Circulation Pump	X	
Hot Gas Solenoid		X

Cube Size*	Time Added to Freeze Cycle (min)
Size 1	0
Size 2	1
Size 3	2
Size 4	3
Size 5	4

*Press "Size" to change the cube size setting.

NORMAL OPERATION

2. HARVEST MODE



- **Har** is displayed and harvest cycle begins.
- The control board stops sending power to the condenser fan and circulation pump while compressor continues to run.
- 120vac is sent to the hot gas valve and water valve from terminal CN11 (Hot Gas NO) on control board. Unit will run water valve to assist in warming the evaporator ice mold to help release the ice cubes. At the same time refilling the water reservoir for the next cycle.
- Hot gas valve is energized allowing hot gas to flow directly to the evaporator. This causes the evaporator to warm further assisting in releasing ice cube so they can fall in the ice bin.

	ON	OFF
Compressor	X	
Condensor Fan		X
Water Valve	X	
Circulation Pump		X
Hot Gas Solenoid	X	

3. DRAIN MODE

- Drain pump will operate in standby mode as long as the unit has power.
- As the aged ice melts, water flows down the drain. Pressure begins to build in the pressure switch hose, activating the (Normally Closed) pressure switch. 120vac is supplied to the pressure switch from the main harness.
- When activated, the pressure switch opens, stopping the 120vac from reaching terminal CN17 (DRAIN RET)
- This tells the board the drain pump needs to run. 120vac is sent out of the board from terminal CN15 (Drain NO) down through the harness to the drain pump to pump out water.
- If the drain pump cannot clear all the water in five (5) min, the unit will shut down and read **drn**.

4. BIN FULL



- **FUL** is displayed, ice bin is full.
- As the ice bin fills up. It gets closer to the ice level sensor bar, causing it to cool.
- Once the sensor cools enough (determined by the bin thermostat setting), the bin thermostat will open. Board outputs 1.5vdc and drops to 0 when thermostat closes. This will signal to the control board that enough ice has been made.



BIN LIGHT

- Use **LIGHT** to control the bin light
- Press the **LIGHT** button repeatedly to cycle through the 14 preset designer colors
- Hold the **LIGHT** button for five seconds to toggle the bin light on or off.

CUBE SIZE ADJUSTMENT

- Pressing the **SIZE** button repeatedly allows you to toggle between the available cube sizes.
- There are five cube sizes possible, where “1” = smallest, “5” = largest.

NOTE: CUBE SIZE VARIATION IS RELATIVELY SMALL. WHEN SET TO “1”, THE CUBES WILL BE HOLLOW, LIKE A THIMBLE OR SHOT GLASS. WHEN SET TO “5”, THE CUBES WILL BE SOLID. ALWAYS LET THE MACHINE MAKE TWO BATCHES OF ICE BEFORE RESETTING THE THICKNESS.

BIN THERMOSTAT

The bin thermostat senses when ice has reached the top of the bin and shuts the machine off. This thermostat is adjusted at the factory for room-temperature operation and normally will not require adjustment.

To check the operation of the bin thermostat, hold three ice cubes in contact with the thermostat tube in the bin. The machine should stop making ice within five minutes. The display will read **FUL**.

Then remove the ice cubes. The machine should then restart within five minutes.

ICE LEVEL ADJUSTMENT

If necessary, the level of ice in the bin can be adjusted by turning the bin thermostat screw with a screwdriver. This screw is just behind the kickplate on the left side of the machine.

- Clockwise: Raises the ice level
- Counterclockwise: Lowers the ice level

All True undercounter ice machines are UL-rated for outdoor use. When installing outdoors, keep in mind that certain regions may experience colder ambient temperatures than others. When this decrease in temperature occurs, the unit may stop producing ice before it is full and begin showing **FUL** on the display. This is caused because the internal thermostat has reached the cut-off temperature. Furthermore, these stainless steel cabinets are very heavily insulated and will retain the cold temperature for long periods of time.

The location of the unit will also play a factor in the false full reading. If the unit is built into a kitchenette area, within stone, brick, or wood etc., this will further delay the reaction time. Basically, even if your temperatures increase during the day, your cabinet may be holding the colder temperature from the evening before.

If your unit is showing a false full reading, rub your hand on the inside ice level bar. Once it senses the warm temperature it will start ice production again. It is recommended during colder periods to increase the ice level.

BREAKER RESET

The breaker switch is located behind the kickplate. If the unit trips, flip the switch down. To reset, flip the switch up.

WATER QUALITY SETTING

Your True Ice™ machine may operate differently depending on the water quality setting of the machine. To determine your water quality, it is recommend to purchase a water quality test kit from a local source.

Low Scale (LSC on the display): When set to LSC, the machine will make ice faster, harvest faster, and require a filter change every 12 months.

High Scale (HSC on the display): When set to HSC, the machine will allow more time for freezing and harvesting ice to compensate for the presence of scale. The water filter should be replaced more frequently.

Simultaneously Press and hold **CLEAN** and **SIZE** for three seconds to toggle between the Low Scale (LSC) and High Scale (HSC) water quality settings on the machine. Set unit to LSC when the total dissolved solids (TDS) are below 300 mg /L. Set unit to HSC when the total dissolved solids (TDS) are above 300 mg /L.

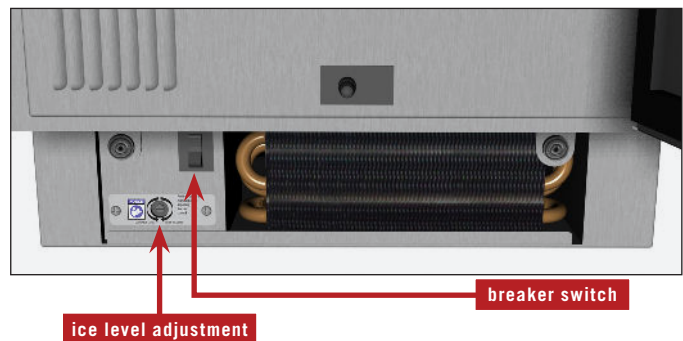

GENERAL MAINTENANCE

INTERIOR COMPONENTS

WATER FILTER REPLACEMENT

SERVICING & REPLACING COMPONENTS

CONDENSER CLEANING

APPLIANCE CARE & CLEANING

DESCALING & SANITIZING

EXTERIOR CLEANING

WINTERIZING INSTRUCTIONS



PRESERVE THE MOMENT®

GENERAL MAINTENANCE

You are responsible for maintaining the ice machine in accordance with the instructions in this manual. Maintenance procedures are not covered by warranty.

True recommends performing the following maintenance procedures a minimum of once every six months to ensure reliable, trouble-free operation.



WARNING! IF YOU DO NOT UNDERSTAND THE NECESSARY PROCEDURES OR SAFETY PRECAUTIONS, CALL YOUR LOCAL TRUE SERVICE REPRESENTATIVE TO PERFORM MAINTENANCE PROCEDURES FOR YOU.



WARNING! TAKE CARE DURING OPERATION, MAINTENANCE, OR REPAIRS TO AVOID CUTS OR PINCHING FROM ANY APPLIANCE PART/COMPONENT.

EXTERIOR CLEANING

Clean the exterior as needed. Follow stainless steel cleaning recommendations (pg. 43) to ensure your machine always looks like new.

DESCALING & SANITIZING

Descale and sanitize every 6 months. See "Descaling & Sanitizing" (pg. 42).

WATER FILTER REPLACEMENT

Replace the water filter at least once every 12 months. More frequent replacement may be required based on your water quality. See "Water Filter Replacement" (pg. 38)

CONDENSER COIL CLEANING

For optimum operation, clean your condenser coil every 6 months. See "Condenser Coil Cleaning" (pg. 39).

Maintenance	Weekly	Semi-Annual	Annual	After Prolonged Shutdown	At Start-Up
Clean Appliance Exterior	X			X	X
Sanitize Ice Machine		X	X	X	X
Descale Ice Machine		X	X	X	X
Clean Condenser Coil		X	X	X	
Change The Water Filter		X	X	X	
Check Ice Quality	X	X	X	X	X

INTERIOR COMPONENTS

See the following for the removal and correct installation of the interior components.

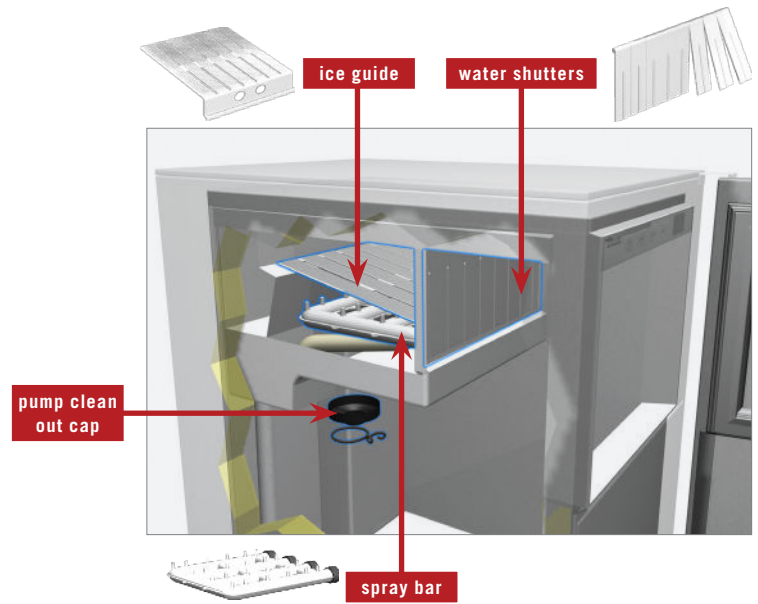

WATER SHUTTER

The water shutter hangs in front of the spray bar and ice guide. It prevents spraying water from escaping the evaporator compartment.

REMOVAL

Lift the shutter rod's ends from the recesses in the sidewall.

INSTALLATION

Insert the shutter rod's ends into the recesses in the sidewall. To be correctly installed, the water shutter must—

- Hang from a shutter rod fully seated in the recessed end supports.
- Conceal the ice guide finger holes.



CORRECT. Ice guide finger holes are hidden; ice guide slotted holes are visible.

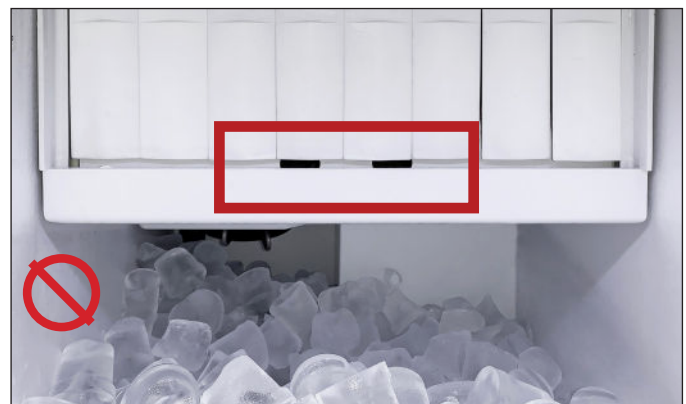

INCORRECT. Ice guide finger holes are visible.

ICE GUIDE

The ice guide sits over the spray nozzles and directs falling ice into the bin.

REMOVAL

Lift the front of the guide and pull the guide forward.

INSTALLATION

Position the ice guide over the spray bar. To be correctly installed, the ice guide must—

- Be firmly positioned over the spray bar.
- Sit with its front edge inside the water trough.
- Have its slots aligned with the spray nozzles.



CORRECT. Ice guide positioned in the guide channel and flush against the back side of the water trough opening.



INCORRECT. Ice guide positioned too far inside the water trough.



INCORRECT. Ice guide positioned outside the water trough.

SPRAY BAR

REMOVAL

Carefully pull the spray bar from the water supply hose.

INSTALLATION

The spray bar, located in the water trough, supplies water to the individual ice cube cups. To be correctly installed, the spray bar must–

- Be positioned with the clean-out caps on the right.
- Sit fully seated and horizontally level.



CORRECT. Spray bar is fully seated, level, and positioned with the clean-out caps on the right.

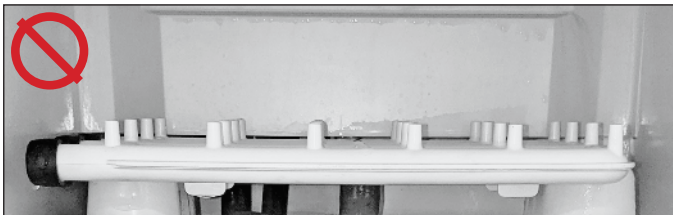

INCORRECT. Spray bar positioned with clean-out caps on the left.



INCORRECT. Spray bar is not fully seated or level.

PUMP CLEAN-OUT CAP

REMOVAL

1. Remove the pump clamp. See fig. 1.
2. Pull the clean-out cap down.

INSTALLATION

3. Slide the clean-out cap over the hole beneath the pump.
4. Reinstall the pump cap clamp.

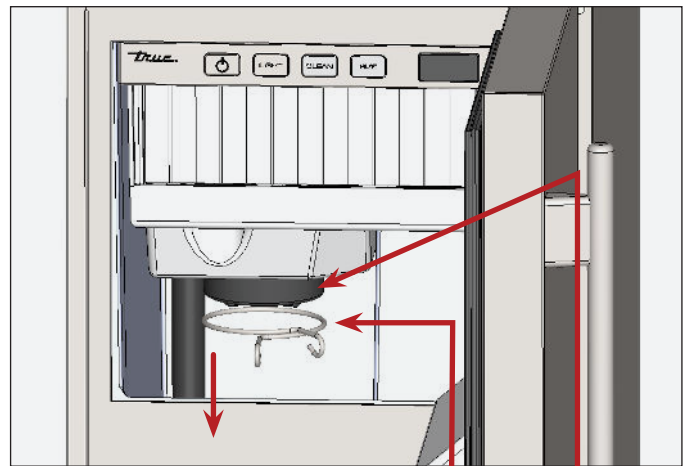

FIG. 1. Pump cap and clamp locations.

clamp pump cap

WATER FILTER REPLACEMENT

NOTE: THE ICE MACHINE WILL NOT MAKE ICE IF THE WATER FILTER IS NOT INSTALLED.

The life expectancy of the filter is twelve months for low-scale water and six months if the water has a high level of scale. The ice machine monitors how long the filter has been in operation and will display **FLT** when the filter needs to be replaced.

NOTE: THE FILTER REPLACEMENT REMINDER WILL SHUT THE ENTIRE UNIT DOWN UNTIL THE REMINDER IS RESET BY PRESSING AND HOLDING THE CLEAN & LIGHT BUTTON.

To order a replacement water filter, go to: <https://store.trueresidential.com/collections/maintenance-1/products/replacement-waterfilter> or contact our parts department at: 844-849-6226 or TrueResidentialParts@TrueMfg.com.



CAUTION! DO NOT INSTALL THE WATER FILTER WHILE THE WATER SUPPLY IS PRESSURIZED. ALWAYS RELIEVE THE WATER PRESSURE BEFORE CHANGING THE FILTER.

1. Press and hold **CLEAN** and **LIGHT** to reset the water filter reminder.
2. If on, press and hold the power button until the display shows **oFF**.
3. Press and hold the power button until the display shows **FiL**. This relieves the water pressure.
4. Rotate the water filter counterclockwise and pull the existing filter from the unit. See fig. 1.

NOTE: IF YOU HAVE DIFFICULTY REMOVING THE WATER FILTER, TURN OFF THE WATER SUPPLY.

5. Press and hold the power button until the display shows **oFF**.

6. Locate the provided lubricant. Then, apply the provided lubricant to both o-rings.
7. Insert the replacement water filter and rotate the filter clockwise. See figs. 2 and 3.
8. If turned off, turn the water supply on.

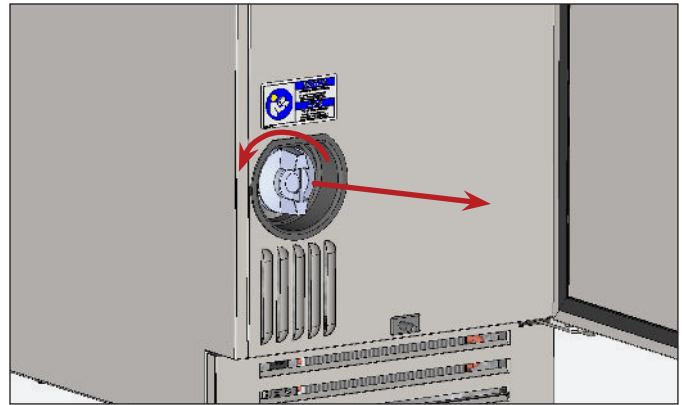

FIG. 1. Rotate the existing water filter counterclockwise.

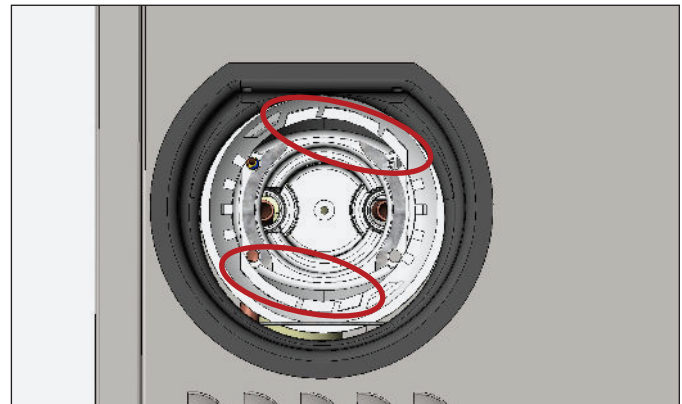

FIG. 2. Align the filter with the filter head's teeth.

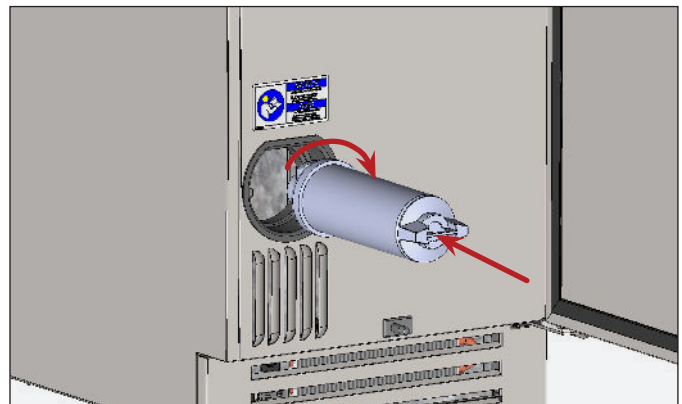

FIG. 3. Insert the replacement water filter and rotate it clockwise.

SERVICING & REPLACING COMPONENTS

- Replace component parts with original equipment manufacturer (OEM) components.
- Contact the dealer or our parts department at **844-849-6226** or **TrueResidentialParts@truemfg.com** for replacement parts.
- Have a licensed service provider service your unit to minimize the risk of possible ignition due to incorrect parts or improper service and to ensure the operator's health and safety.
- Unplug the ice machine before cleaning or making any repairs. Powering off an electronic control may not remove power from all components.

CONDENSER CLEANING INSTRUCTIONS

Keeping the condenser coil clean will minimize required service and lower electrical cost.

The condenser coil should be cleaned by removing dust and other build-up from the tube assembly with vacuum or a clean rag.

1. Remove kickplate.
2. Vacuum or use clean rag to remove dust build-up from coil.
3. Reinstall kickplate.



APPLIANCE CARE & CLEANING



CAUTION: DO NOT USE ANY STEEL WOOL, ABRASIVE OR CHLORINE BASED PRODUCTS TO CLEAN STAINLESS STEEL SURFACES.

STAINLESS STEEL OPPONENTS

There are three basic things which can break down your stainless steel’s passivity layer and allow corrosion to form.

- Scratches from wire brushes, scrapers, and steel pads are just a few examples of items that can be abrasive to stainless steel’s surface.
- Deposits left on your stainless steel can leave spots. You may have hard or soft water depending on what part of the country you live in. Hard water can leave spots. Hard water that is heated can leave deposits if left to sit too long. These deposits can cause the passive layer to break down and rust your stainless steel. All deposits left from food prep or service should be removed as soon as possible.
- Chlorides are present in table salt, food, and water. Household and industrial cleaners are the worst type of chlorides to use.

STAINLESS STEEL CLEANING AND RESTORATION

Stainless steel cleaners must be free of phosphates, chlorine, chloride, and ammonia.

TRUE offers environmentally-friendly cleaner and polish through our True Store at <https://store.trueresidential.com/products/stainless-steel-clean-polish-kit>

CUSTOM PAINTED APPLIANCES AND HARDWARE

For painted doors and other surfaces, use a mild solution of soap and water with a soft microfiber cloth.

APPLIANCE CARE & CLEANING

8 TIPS TO HELP PREVENT RUST ON STAINLESS STEEL

- **Maintain the Cleanliness of Your Equipment** – Avoid build-up of hard stains by cleaning frequently. Use cleaners at the recommended strength (alkaline chlorinated or non-chloride).
- **Use the Correct Cleaning Tools** – Use non-abrasive tools when cleaning your stainless steel products. The stainless steel's passive layer will not be harmed by soft cloths and plastic scouring pads.
- **Clean Along Polishing Lines** – Polishing lines ("grain") are visible on some stainless steels. Always scrub parallel to polishing lines when visible. Use a plastic scouring pad or soft cloth when you cannot see the grain.
- **Use Alkaline, Alkaline-Chlorinated or Non-Chloride Cleaners** – While many traditional cleaners are loaded with chlorides, the industry is providing an ever increasing choice of non-chloride cleaners. If you are not sure of your cleaner's chloride content, contact your cleaner supplier. If they tell you that your present cleaner contains chlorides, ask if they have an alternative. Avoid cleaners containing quaternary salts, as they can attack stainless steel, causing pitting and rusting.
- **Rinse** – When using chlorinated cleaners, you must rinse and wipe dry immediately. It is better to wipe standing cleaning agents and water as soon as possible. Allow the stainless steel equipment to air dry. Oxygen helps maintain the passivity film on stainless steel.
- **Never Use Hydrochloric Acid (Muriatic Acid) on Stainless Steel** – Even diluted, hydrochloric acid can cause corrosion, pitting and stress corrosion cracking of stainless steel.
- **Water Treatment** – To reduce deposits, soften hard water when possible. Installation of certain filters can remove corrosive and distasteful elements. Salts in a properly maintained water softener can also be to your advantage. Contact a treatment specialist if you are not sure of the proper water treatment.
- **Regularly Restore & Passivate Stainless Steel** – Stainless steel gets its stainless properties from the protective chromium oxides on its surface. If these oxides are removed by scouring, or by reaction with harmful chemicals, then the iron in the steel is exposed and can begin to oxidize, or rust. Passivation is a chemical process that removes free iron and other contaminants from the surface of stainless steel, allowing the protective chromium oxides to re-form.

DESCALING AND SANITIZING

Please follow the instructions below when descaling and sanitizing your machine.

Hold the **CLEAN** button for three seconds to initiate the automatic descaling sequence. The descaling sequence begins by harvesting all the ice from the evaporator. Once the harvest is complete, the machine will beep and display **Add** indicating it is time to add cleaning chemicals to the unit.

After the chemicals have been added, the machine will go through a sequence of rinse and drain cycles to descale the machine and drain all the descaling chemicals from the unit. Once complete, the machine will resume whatever it was doing to prior to descaling. If the machine was making ice prior to pressing the **CLEAN** button, it will resume ice making. If the machine was off before **CLEAN** was pressed, it will turn off when descaling is complete.

NOTE: THE DESCALING SEQUENCE CAN BE CANCELED BY HOLDING THE CLEAN BUTTON FOR THREE SECONDS.

A full descaling should be performed every six months. Descaling also involves removing key ice machine parts and rinsing them and the inside of the machine with ice machine descaler.

Sanitizing the ice machine is done to remove any biological contamination that may have occurred. That process is identical to the descaling process above except that a sanitizing agent is used in place of the descaling chemicals.

WARNING: WEAR RUBBER GLOVES AND EYE PROTECTION WHEN HANDLING ICE MACHINE DESCALER OR SANITIZER.

CAUTION: DO NOT MIX DESCALER AND SANITIZER TOGETHER.

PERFORM THE FOLLOWING STEPS EVERY SIX MONTHS TO FULLY DESCAL OR SANITIZE YOUR MACHINE.

DESCALING

PERFORM STEPS 1-4 WHEN ONLY A LIGHT DESCALING IS NEEDED.

1. Remove the ice from bin.
2. Press and hold the **CLEAN** button for three seconds.
3. When machine says **Add**, pour 6 fl. oz. of undiluted True Ice® Machine Descaler into the spray compartment behind the water shutters.
4. Wait until the rinsing is complete (30 minutes).
5. Remove the four ice machine parts illustrated below.
6. Create a descaling solution by mixing 10 fl. oz. of undiluted True Ice® Machine Descaler with 1 gallon of water.
7. Using 1/2 of solution, clean removed parts with a brush then soak them for 20 minutes.
8. Use the remaining solution to descale the ice bin, the door, the door gasket, the inside of spray compartment, and the top of evaporator.
9. Rinse all parts with clean water.

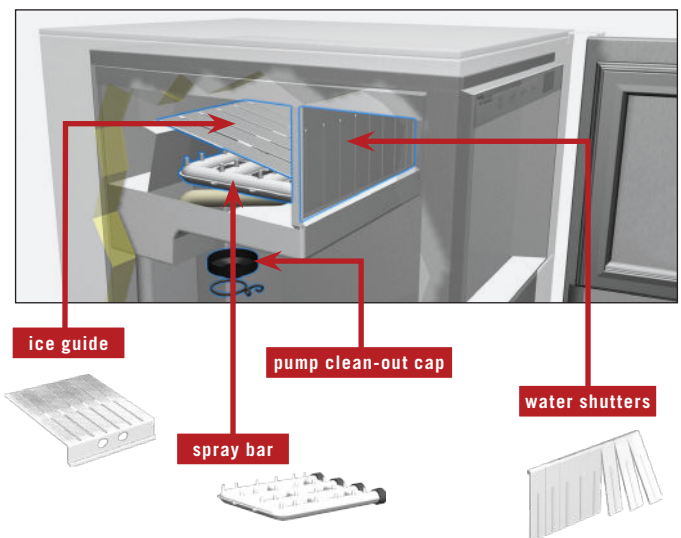

SANITIZING

PERFORM STEPS 5-8 WHEN ONLY A LIGHT SANITIZING IS NEEDED.

1. Mix 1.5 fluid ounces (3 tablespoons) of 5.25% hypochlorite solution (chlorine bleach) with 3 gallons of warm water.
2. Use 1/2 of the solution to sanitize the removed parts. Soak the parts in the solution. Do not rinse the parts after sanitizing.
3. Use the remaining solution to sanitize the interior surfaces of the machine and the bin. Do not rinse the sanitized areas.
4. Replace all components.
5. Press and hold the **CLEAN** button for three seconds.
6. When the machine says **Add**, pour 2 teaspoons of 5.25% hypochlorite solution (chlorine bleach) into the spray compartment.
7. When the cleaning cycle is complete, the machine will resume its previous mode (either **OFF** or **ICE**).
8. Immediately rinse off and dry any exterior areas where sanitizing solution may have spilled.

EXTERIOR CLEANING

Wipe with a damp cloth to remove dust and dirt. Use a solution of mild dish soap and water if a greasy residue persists. Wipe dry with a clean, soft cloth. Never use abrasives, chlorinated or citrus-based cleaners on exterior panels.

WINTERIZING INSTRUCTIONS

NOTICE: DO NOT ALLOW THE ICE MACHINE TO BE EXPOSED TO TEMPERATURES BELOW 32°F (0°C) WITHOUT WINTERIZING THE UNIT AS THIS WILL CAUSE ANY WATER IN THE MACHINE TO FREEZE. FAILURES CAUSED BY EXPOSURE TO FREEZING TEMPERATURES ARE NOT COVERED BY THE WARRANTY.

Use the following instructions to prepare your ice machine for storage or winterization:

1. Descale and sanitize the ice machine per the instructions in this manual or reference the cleaning and maintenance videos on our YouTube channel at True Residential.
2. Turn off the water supply.
3. Disconnect the incoming water line from the back of the unit.
4. Remove the water filter by twisting it counter clockwise and pulling it out of the unit. Discard the water filter.
5. Press power until the display shows **FiL**. Leave the machine on for 20 sec, and then press power to turn the unit off.
6. Drain the evaporator compartment by removing the pump clean-out cap.
7. Pour 1 gallon of propylene glycol (RV antifreeze) into the bin drain to fill the drain pump.
8. Once the drain pump shuts off and all the propylene glycol is drained, unplug the unit or turn off the circuit breaker.
9. Wipe down the interior bin with a dry clean cloth.
10. Re-install the pump clean-out cap.

RESTARTING AFTER WINTERIZING INSTRUCTIONS

Use the following instructions to restart your ice machine after winterization:

1. Install a new water filter in the unit.
2. Reconnect the incoming water line and turn on the water supply.
3. Plug in the unit.
4. Sanitize the ice machine per the instructions on page 66.
5. Press the power button to start ice making.

NOTE: THE FRESH WATER THAT IS INTRODUCED DURING SANITIZING AND START-UP WILL FLUSH THE PROPYLENE GLYCOL DOWN THE DRAIN.

VERIFYING COMPONENT VOLTAGE

DOOR CLOSING & SEALING ISSUES

THERMISTOR LOCATIONS

THERMISTOR VALUES

FREEZE CYCLE SEQUENCE & CHART

HARVEST CYCLE SEQUENCE & CHART

FREQUENTLY ASKED QUESTIONS

WIRING DIAGRAM



PRESERVE THE MOMENT®

TROUBLESHOOTING

VERIFYING COMPONENT VOLTAGE (AT CONTROL BOARD)

When testing component voltage at the control board, verify the COM terminal for that component has 115vac.

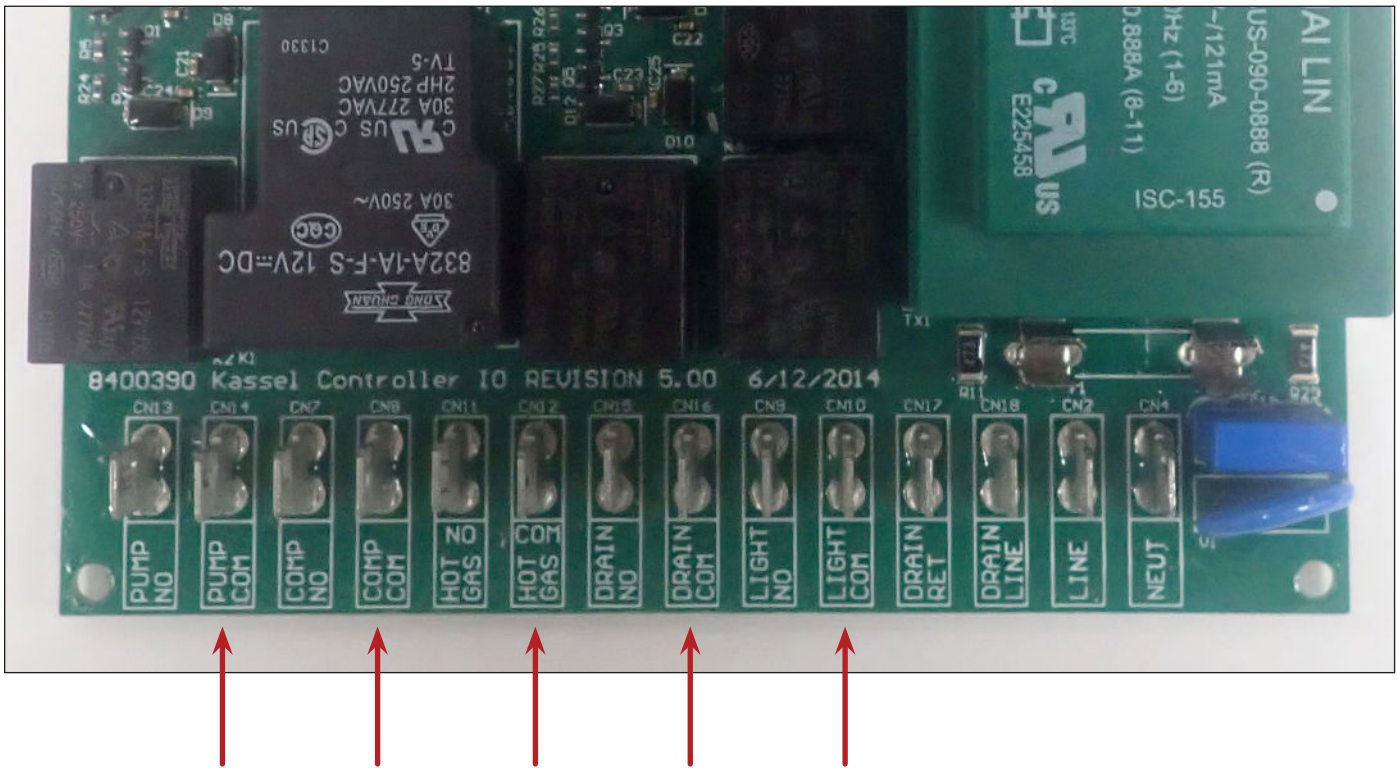

DOOR CLOSING & SEALING ISSUES

Doors and drawers closing and sealing properly are critical to the unit's functionality, efficiency, and longevity. Take extra care of units that are susceptible to outdoor weather conditions. Failure to maintain door gaskets may result in high temp alarms, mold build up, doors not closing or sealing, and failures to the refrigeration system's operation.

NOTE: GASKETS ARE NOT COVERED UNDER PARTS AND LABOR WARRANTY AS THEY ARE A WEAR AND TEAR ITEM. PLEASE CONTACT THE PARTS DEPARTMENT FOR REPLACEMENT GASKETS AT 844-849-6226.

REQUIRED TOOLS

Required tools include (but may not be limited to) the following:

- 3/8" Socket wrench
- Phillips Screwdriver or Bit Driver

GASKET CLEANING:

- Turn the unit off before cleaning.
- Do **NOT** use sanitizing solution to clean gaskets. Use mild detergent and water with a soft cloth. A water and baking soda paste may be used to remove tough stains.
- For mold or mildew, use a 1:10 part ratio of bleach to water and a soft cloth to wipe down the interior and affected areas.
- Rinse and dry thoroughly.

STAINLESS STEEL

STEP 1: LEVEL

Ensure the cabinet is level with all leveling legs in place and touching the ground. See fig. 1.

NOTE: DO NOT REMOVE THE LEVELING FEET.

STEP 2: DOOR CAM CLOSURES

Ensure the door cam closers are securely in place. See fig. 2.

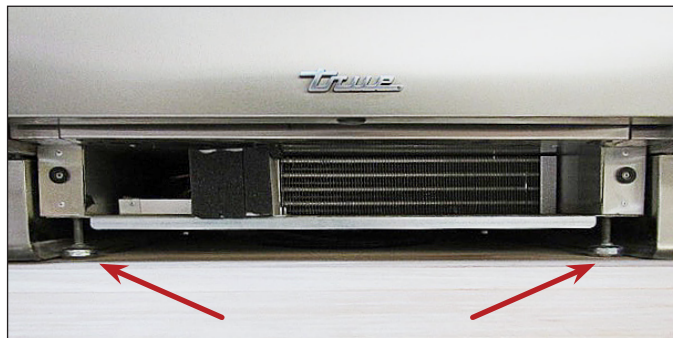

FIG. 1. Front leveling leg locations.

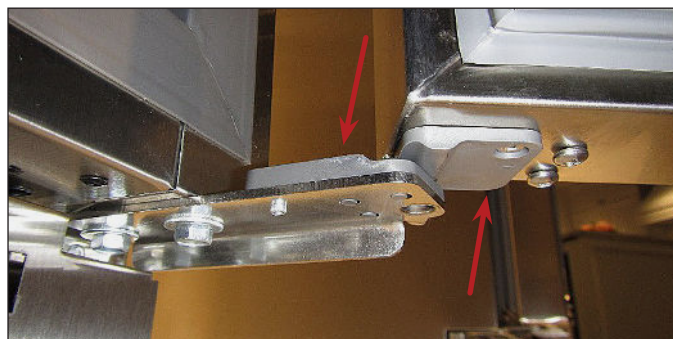

FIG. 2. Door cam closer locations.

STAINLESS STEEL (CONT.)

STEP 3: GASKET

Make sure the gasket is fully seated in the gasket base of the door and flush against cabinet when the door is closed.

If the gasket is torn or damaged, replace the gasket. See fig. 3.

STEP 4: DOOR ALIGNMENT

A door out of alignment can cause a reversed polarity between the magnets in the door gasket and the cabinet front. This forces the gasket away and prevents the door from pulling securely closed, as shown in fig. 4a.

1. Loosen the bottom hinge and adjust the door alignment.
2. When the gasket corners seal against the cabinet opening (see fig. 4b), tighten the lower hinge bolts (see fig. 4c).

STEP 5: DOOR SWITCH

Ensure the door switch plunger does not make contact with the gasket or the door's bottom edge. See fig. 5.

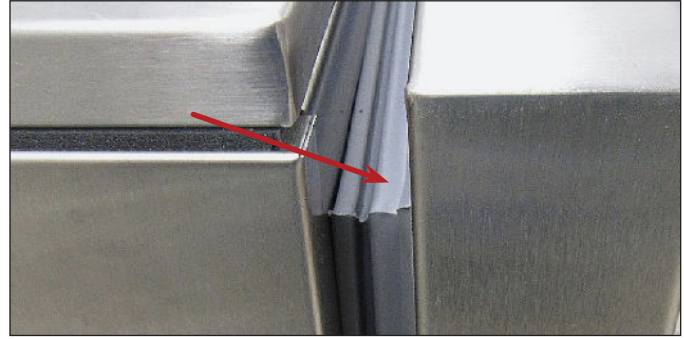

FIG. 3. Fully-seated gasket.

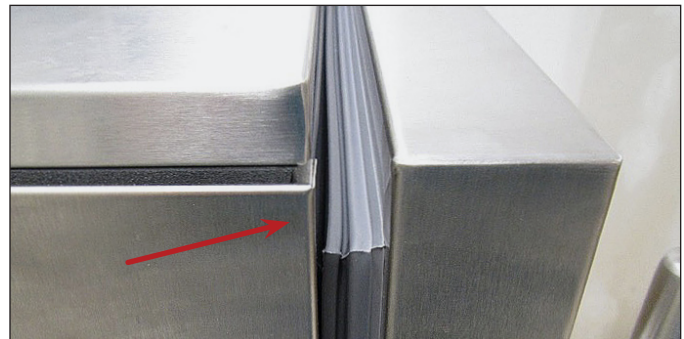

FIG. 4A. Incorrect gasket seal.

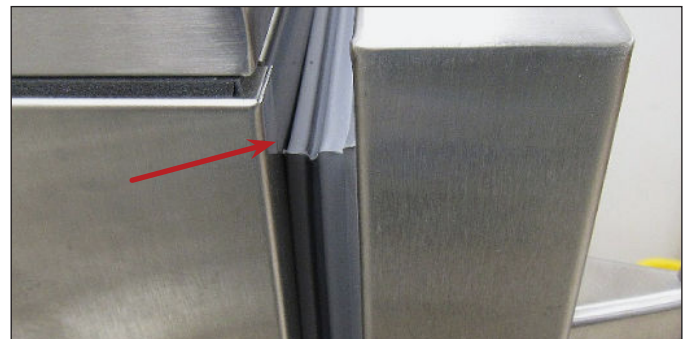

FIG. 4B. Correct gasket seal.



FIG. 5. Door switch plunger location.

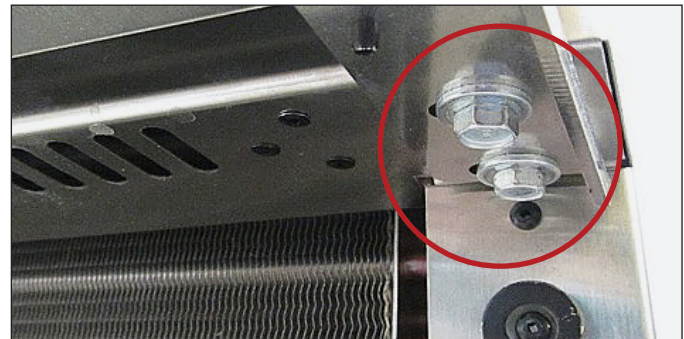

FIG. 4C. Bottom hinge bolt locations.

OVERLAY

STEP 1: LEVEL

Ensure the cabinet is level with all leveling legs in place and touching the ground. See fig. 1.

NOTE: DO NOT REMOVE THE LEVELING FEET.

STEP 2: GASKET

Make sure the gasket is fully seated in the gasket base of the door and flush against cabinet when the door is closed. See fig. 2.

If the gasket is torn or damaged, replace the gasket.

STEP 3: GASKET CHANNEL

If the gasket has a wave or a bow, remove the gasket and inspect the gasket channel on the door.

- If the gasket channel is not straight, square and flush to the door, inspect the installation of the overlay panel. Check the screws that secure the panel to the door.

NOTE: TRUE RECOMMENDS USING COUNTERSUNK SCREWS SO THE GASKET IS COMPLETELY SEATED IN THE CHANNEL.

- If the gasket channels are bowed around the door or the mitered corners have separated (figs. 3a and 3b) this may be the result of an improper install of the panel or overtightening of the panel screws. If so, the door likely needs to be replaced.

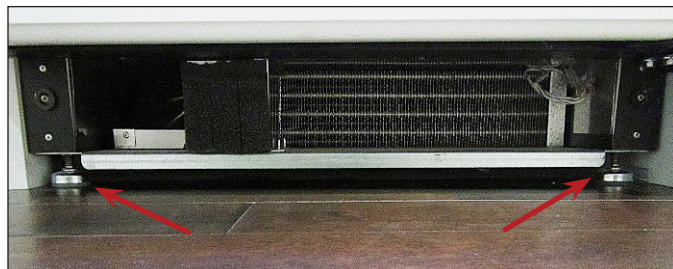

FIG. 1. Front leveling leg locations.

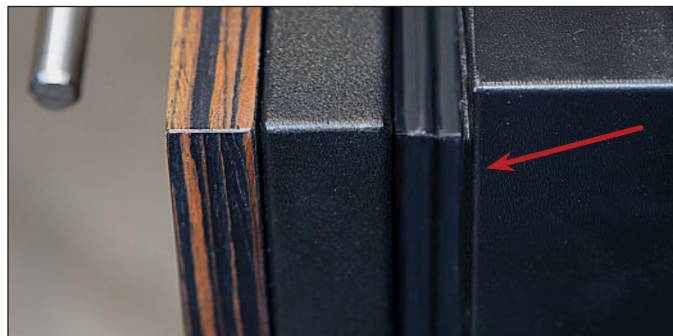

FIG. 2. Fully seated gasket.



FIG. 3A. Bowed gasket channel.



FIG. 3B. Bowed gasket channel.

OVERLAY (CONT.)

STEP 4: DOOR ALIGNMENT

A door out of alignment can cause a reversed polarity between the magnets in the door gasket and the cabinet front. This forces the gasket away and prevents the door from pulling securely closed.

Overlay model doors have three adjustment points (see fig. 9a).

- Upper door bracket (fig. 4b)
 - Lower door bracket (fig. 4c)
 - Lower hinge bracket (fig. 4c)
1. Loosen the bottom hinge and adjust the door alignment.
 2. When the gasket corners seal against the cabinet opening (see figs. 5a and 5b), tighten the lower hinge bolts.
 3. Make any final adjustments with the upper and lower hinge brackets secured to the door. See figs. 4a-4c.

STEP 5: DOOR SWITCH

Ensure the door switch plunger does not make contact with the gasket or the door's bottom edge. See fig. 6.



FIG. 4A. Adjustment point locations.

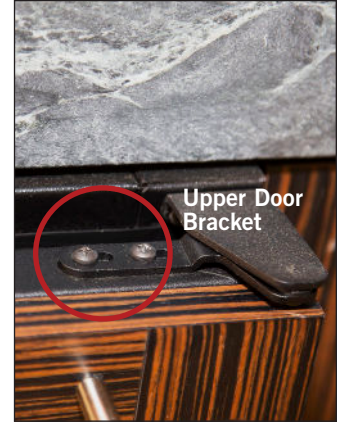

FIG. 4B. Upper door adjustment locations.

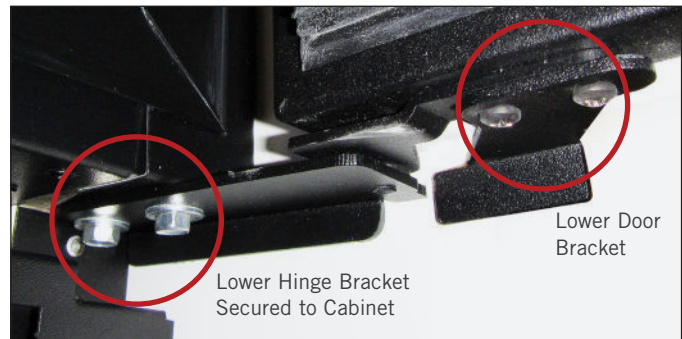

FIG. 4C. Lower door adjustment locations.



FIG. 5A. Correct gasket seal.



FIG. 6. Door switch plunger location.

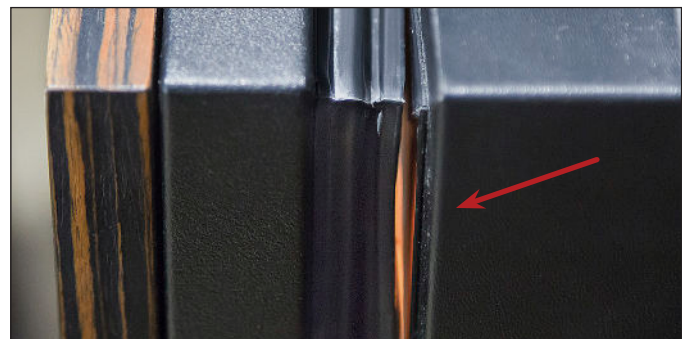

FIG. 5B. Incorrect gasket seal.

THERMISTOR LOCATIONS & VALUES

THERMISTOR 1 (T1)

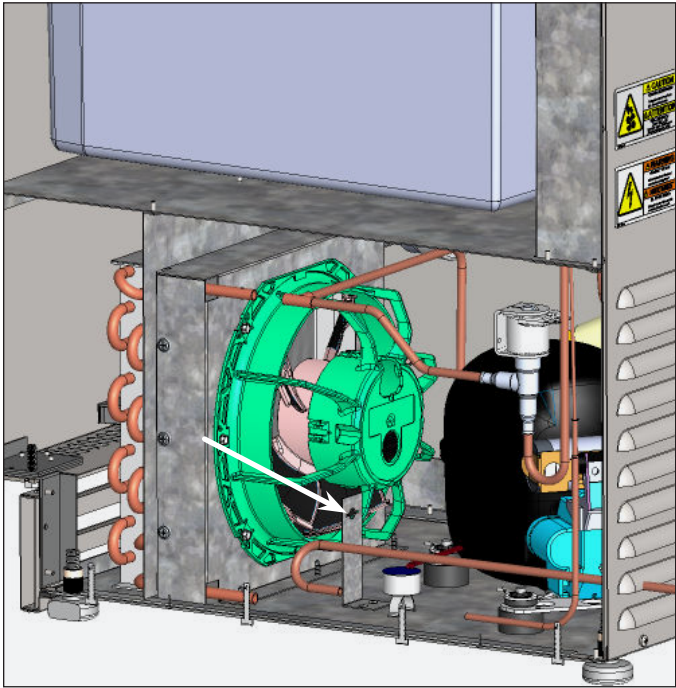

FIG. 1. Thermistor 1 located on the thermistor bracket near the condensor fan.

THERMISTOR 2 (T2)

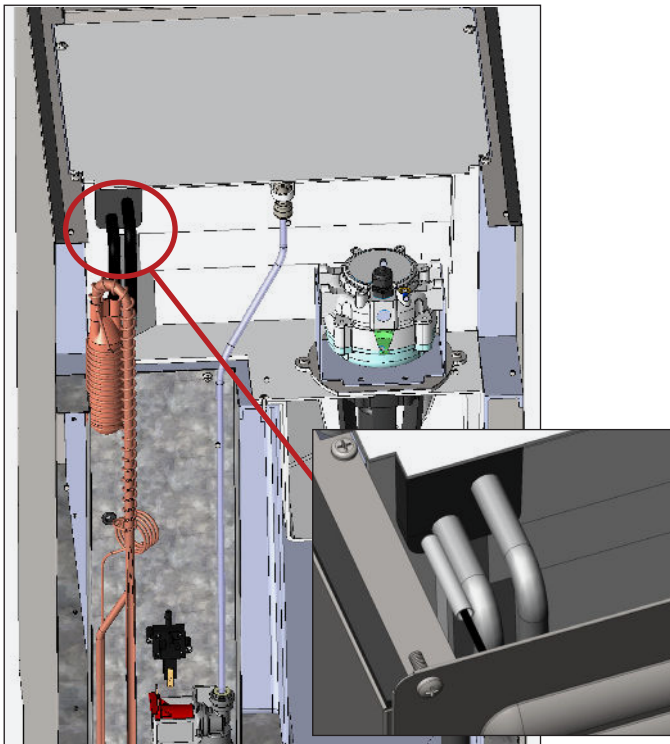

FIG. 2. Thermistor 2 located on the suction line. Position at 9 o'clock on the horizontal section.

Thermistor Values

Temperature		R_NOM
°F	°C	Ω
-40	-40	338253
-31	-35	243546
-22	-30	177499
-13	-25	130642
-4	-20	97211
5	-15	72992
14	-10	55351
23	-5	42325
32	0	32654
41	5	25387
50	10	19898
59	15	15707
68	20	12490
77	25	9998
86	30	8056
95	35	6531
104	40	5328
113	45	4371
122	50	3606
131	55	2990
140	60	2493
149	65	2088
158	70	1758
167	75	1486
176	80	1262

TROUBLESHOOTING

FREEZE CYCLE SEQUENCE & CHARTS

In freeze mode, the condenser and circulation pump motors power on. If this is our first cycle we will add 3 min to this freeze cycle.

The initial freeze cycle time is 10 min. Then, the additional freeze time is added (via condenser air thermistor (t1)). This variable time is based on cube size and scale setting.

For cube size, see added times in the cube size table.

Cube Size*	Time Added to Freeze Cycle (min)
Size 1	0
Size 2	1
Size 3	2
Size 4	3
Size 5	4

*Press "Size" to change the cube size setting.

See the freeze cycle charts for estimated total cycle times.

Estimated total cycle times consist of initial freeze cycle time, variable freeze time, and cube size freeze time.

First Freeze Cycle: Low Scale Cube Size 2				
Estimated Ambient Temperature		Condenser Outlet Temperature		Estimated Total Cycle Time
°F	°C	°F	°C	
50	10	65	18.3	22:40
70	21.1	85	29.4	22:55
85	29.4	100	37.8	24:44
100	37.8	115	46.1	32:18

First Freeze Cycle: High Scale Cube Size 2				
Estimated Ambient Temperature		Condenser Outlet Temperature		Estimated Total Cycle Time
°F	°C	°F	°C	
50	10	65	18.3	25:40
70	21.1	85	29.4	25:55
85	29.4	100	37.8	27:44
100	37.8	115	46.1	32:18

Second Freeze Cycle: Low Scale Cube Size 2				
Estimated Ambient Temperature		Condenser Outlet Temperature		Estimated Total Cycle Time
°F	°C	°F	°C	
50	10	65	18.3	22:40
70	21.1	85	29.4	22:55
85	29.4	100	37.8	24:44
100	37.8	115	46.1	32:18

Second Freeze Cycle: High Scale Cube Size 2				
Estimated Ambient Temperature		Condenser Outlet Temperature		Estimated Total Cycle Time
°F	°C	°F	°C	
50	10	65	18.3	22:40
70	21.1	85	29.4	22:55
85	29.4	100	37.8	24:44
100	37.8	115	46.1	29:18

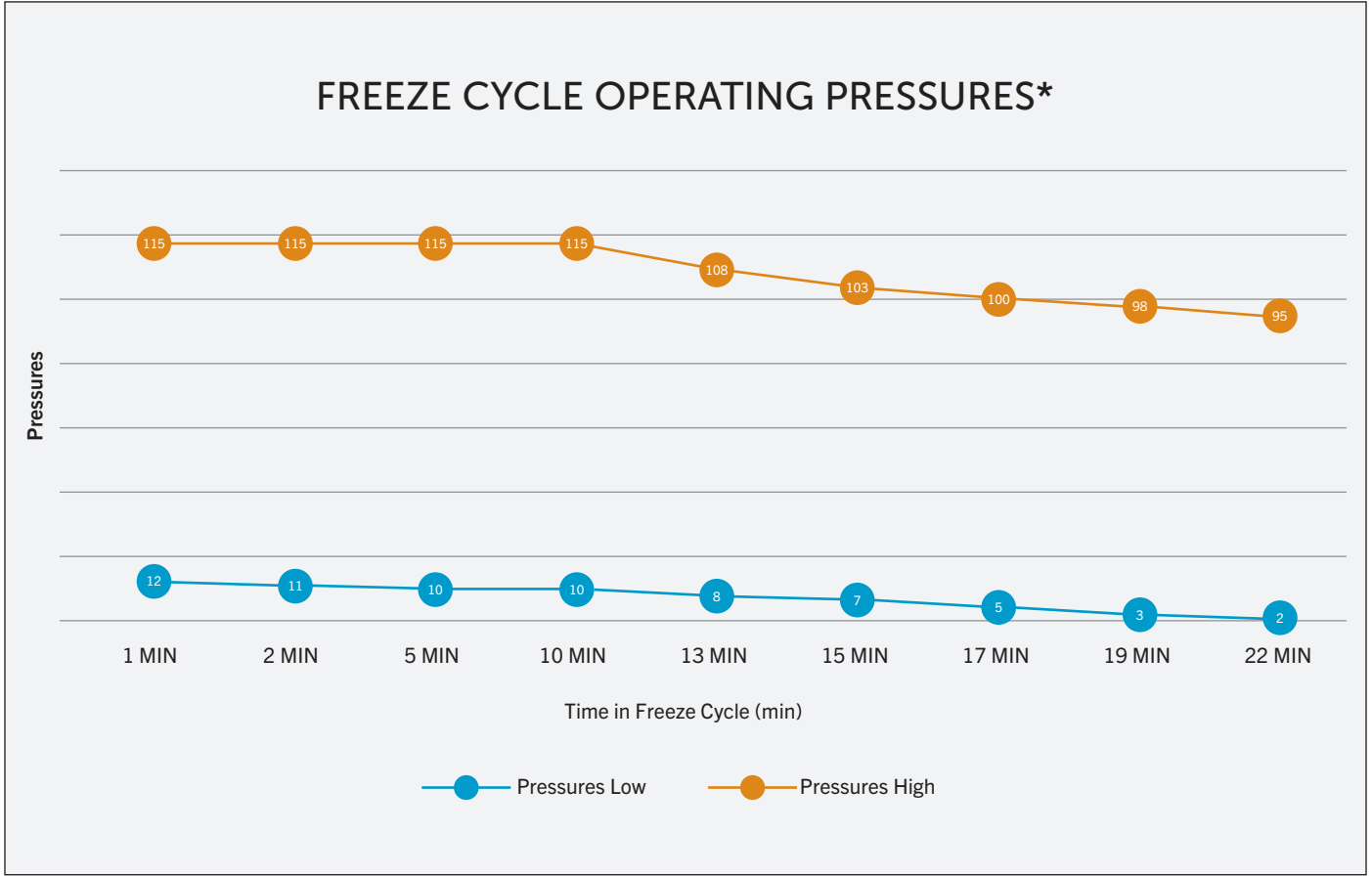

***PRESSURES WILL VARY BASED ON AMBIENT CONDITIONS; CHART REFLECTS AMBIENT 75°F (23.9°C).**

TROUBLESHOOTING

HARVEST CYCLE SEQUENCE & CHARTS

When the unit changes from the freeze cycle to the harvest cycle, the compressor continues to run, hot gas solenoid valve and the water valve energize. The circulation pump deenergizes.

Harvest time is solely based on the condenser air thermistor (t1).

NOTE: A DIRTY CONDENSER COIL CAN AFFECT HARVEST TIMES.

Harvest Cycle: Low Scale

Estimated Ambient Temperature	Condenser Outlet Temperature	Estimated Total Cycle Time (m:ss)
55°F (12.8°C)	70°F (21.1°C)	4:01
65°F (18.3°C)	80°F (26.7°C)	3:06
75°F (23.9°C)	90°F (32.2°C)	2:40
85°F (29.4°C)	100°F (37.8°C)	1:44
95°F (35°C)	110°F (43.3°C)	1:18
105°F (40.6°C)	120°F (48.9°C)	1:01

Harvest Cycle: High Scale

Estimated Ambient Temperature	Condenser Outlet Temperature	Estimated Total Cycle Time (m:ss)
55°F (12.8°C)	70°F (21.1°C)	4:46
65°F (18.3°C)	80°F (26.7°C)	3:41
75°F (23.9°C)	90°F (32.2°C)	2:45
85°F (29.4°C)	100°F (37.8°C)	2:01
95°F (35°C)	110°F (43.3°C)	1:27
105°F (40.6°C)	120°F (48.9°C)	1:04

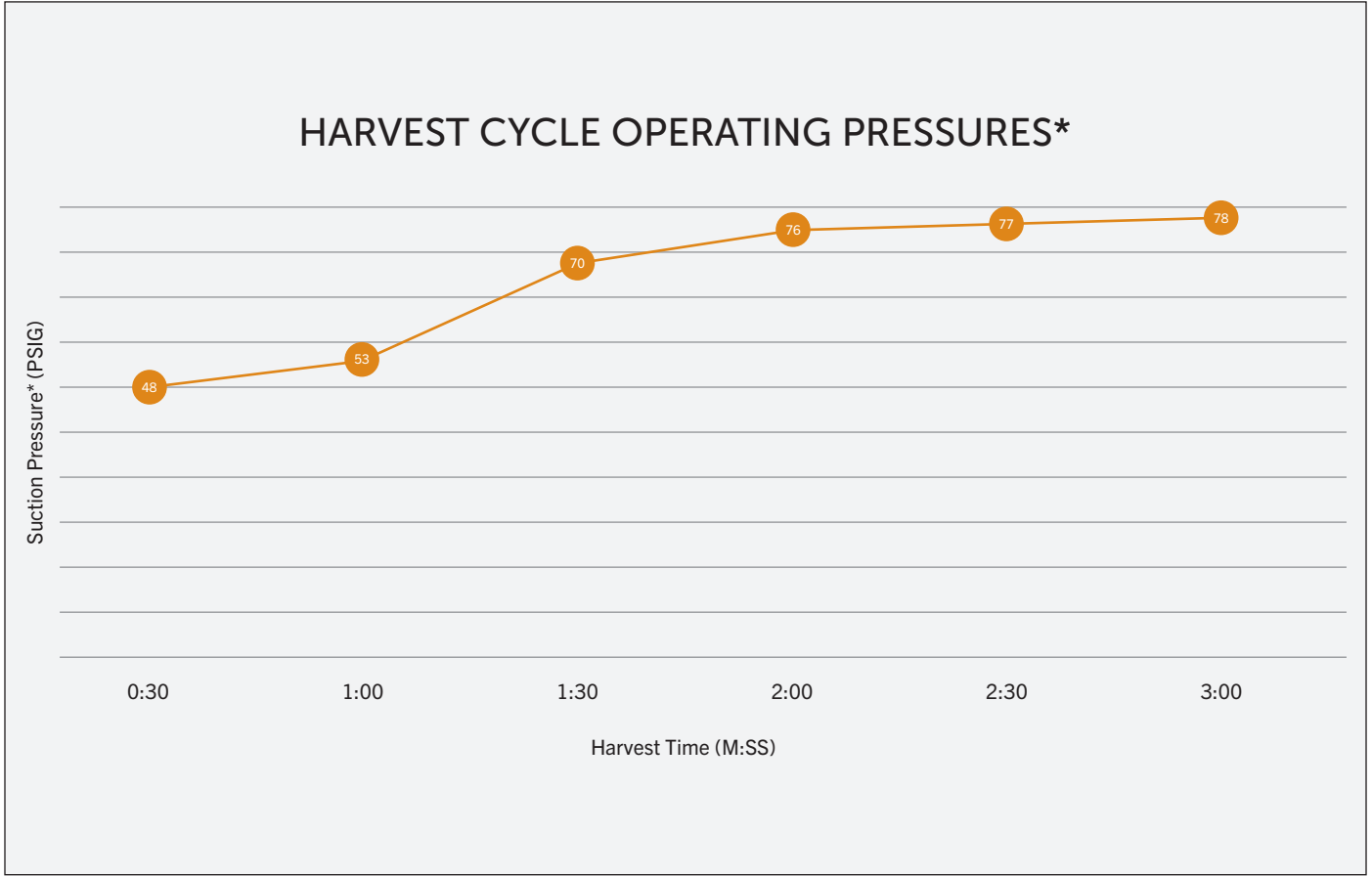

***PRESSURES WILL VARY BASED ON AMBIENT CONDITIONS; CHART REFLECTS AMBIENT 75°F (23.9°C).**

FREQUENTLY ASKED QUESTIONS

Q.WHY IS THE MACHINE RUNNING BUT NOT MAKING ANY ICE?

A.The machine will run but not make ice if there is no water supplied to the machine. Check to make sure the water is turned on and that the water filter is properly installed and fully engaged by rotating 1/4 turn clockwise.

Q.WHY DOES THE MACHINE SAY “FUL” BUT THE ICE BIN ISN’T FULL?

A.This is caused by an improperly adjusted thermostat. Adjust the thermostat as needed. See Outdoor Use section for units in outdoor locations.

Q.WHY IS THERE WARM AIR COMING FROM THE BOTTOM/FRONT OF THE ICE MACHINE (KICKPLATE AREA)?

A.This is normal as heat dissipation is part of the ice making process for this machine.

Q.WHY IS THE ICE MACHINE MAKING LESS ICE THAN BEFORE?

A.If the ambient temperature or the water temperature significantly rises, the amount of ice the machine can make will go down. Likewise, if the condenser coil becomes obstructed or dirty, ice production will drop. For optimal ice production, make sure the front of the condenser coil (behind the kickplate) is clean.

Q.WHY DOESN'T THE MACHINE MAKE ICE AFTER I PUT IT THROUGH A CLEAN CYCLE?

A.After cleaning, the machine will resume doing whatever it was doing before cleaning. If you want it to make ice after a clean, make sure it is in the **ICE** mode when you press the **CLEAN** button to start cleaning.

Q.WHY IS MY ICE MACHINE NOT MAKING FULL CUBES?

A.Your unit may need to be descaled and/or the water filter may need to be changed. Verify the ice cube guide and shutters are properly mounted.

TROUBLESHOOTING

WIRING DIAGRAM

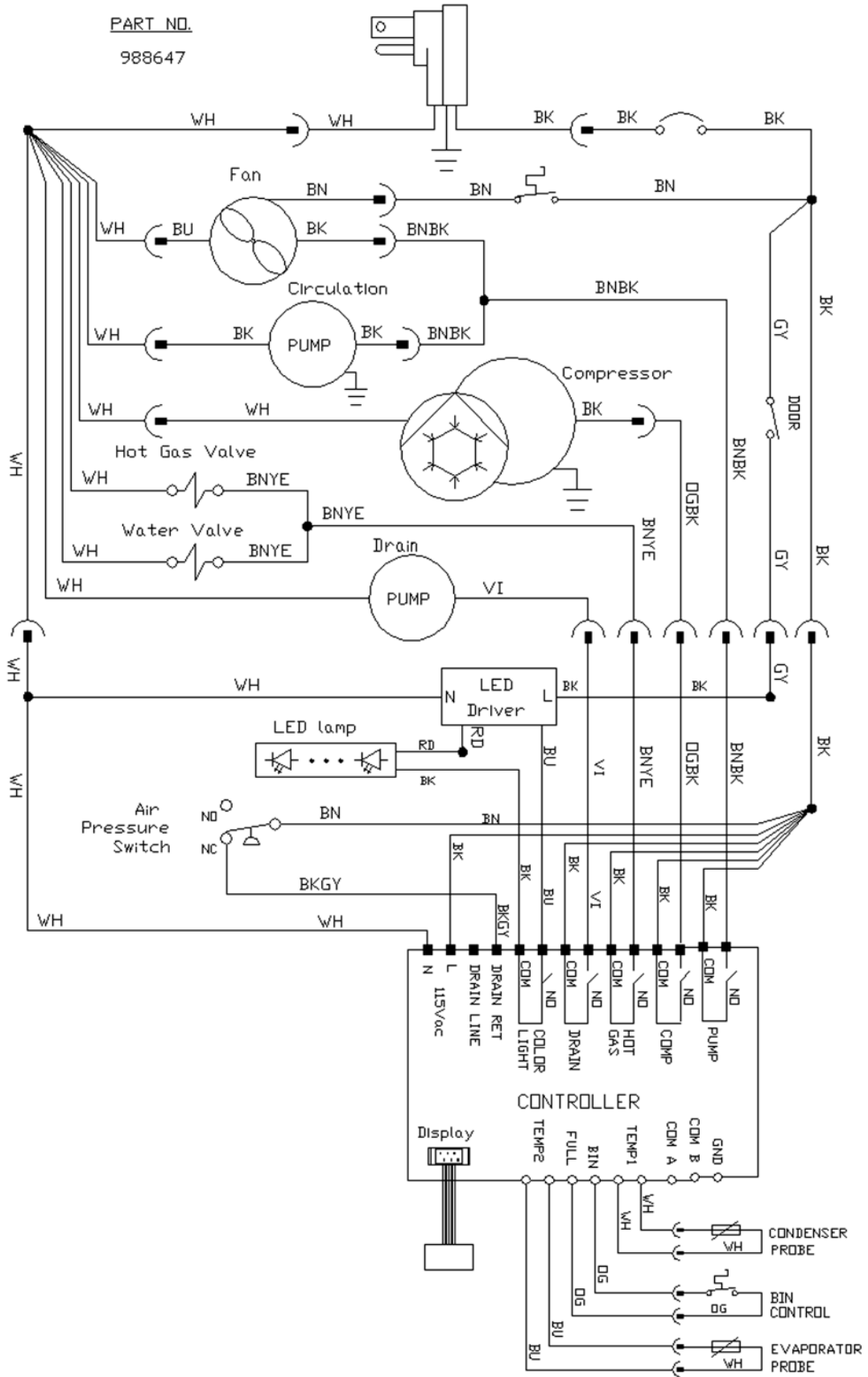

NOTES

CONTACT US

true-residential.com

636.240.2400 | toll free 888.616.8783



PRESERVE THE MOMENT®



811685-A

ST_237883_10.24